

LYSAGHT® LOCKED SEAM®

ROOFING AND WALLING SOLUTIONS

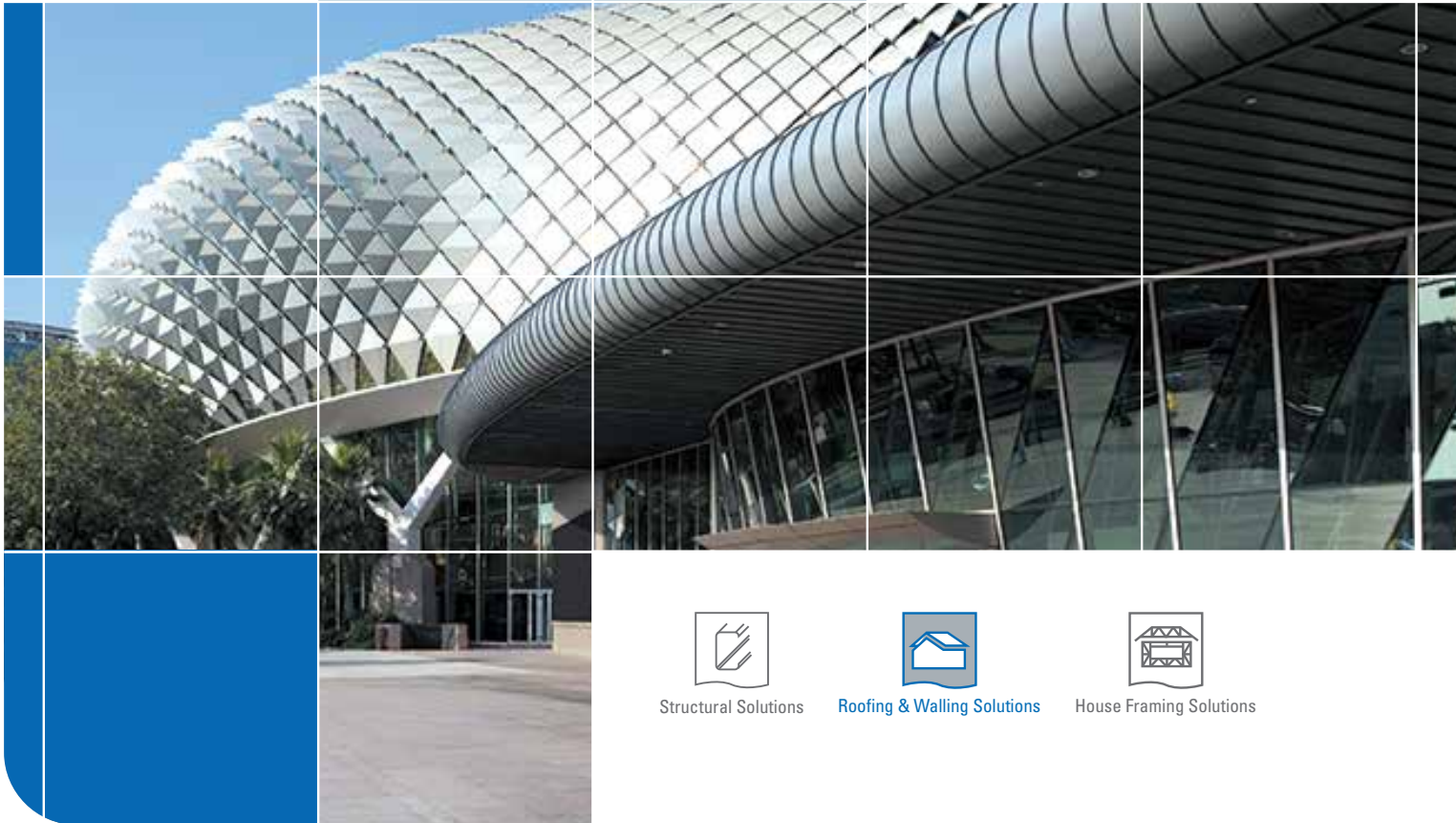

Structural Solutions



Roofing & Walling Solutions



House Framing Solutions



Pit Building



Residential at Hong Guan Ave



Indoor Sport Hall, School Upgrading Programme, West Spring Secondary School



Residential at Ooi Tiong Nam



The Premiere (Design, Build & Sell Scheme)



Singapore Flyer, Outdoor Retail



PRODUCT DESCRIPTION

LYSAGHT® LOCKED SEAM® roof profile is an engineered high quality and lightweight standing seam roof profile, designed as a fully-supported roof and wall cladding for curved, pitched and tapered conditions. LYSAGHT® LOCKED SEAM® standing seam profile is economical, durable, which can be adapted to contemporary architecture.

LYSAGHT® LOCKED SEAM® roof profile offers multiple design options in :

1. Straight sheets
2. Smooth curved sheets without crimped marks
3. Tapered sheets
4. Tapered curved sheets

LYSAGHT® LOCKED SEAM® roof profile require a solid substrate such as LYSAGHT® SPANDEK® or LYSAGHT® TRIMDEK®

LYSAGHT® LOCKED SEAM®

LYSAGHT® LOCKED SEAM® profile provides a modest and discreet roof at 32mm seam height. The specially designed height of the standing seam contributes to the modernity, lightness and regularity of the roof architecture. Minimalism and simplicity effect is distinguished and it gives the roof distinctive appearance of nostalgic complementing modernism when it is used on more complex shapes.

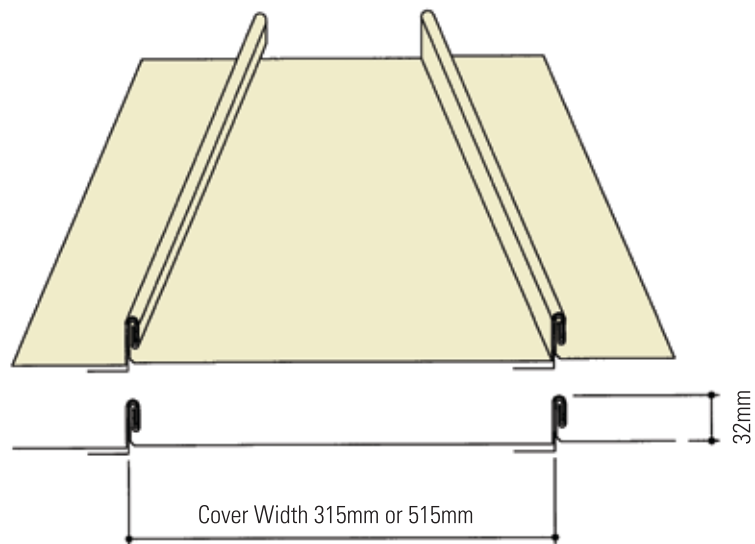
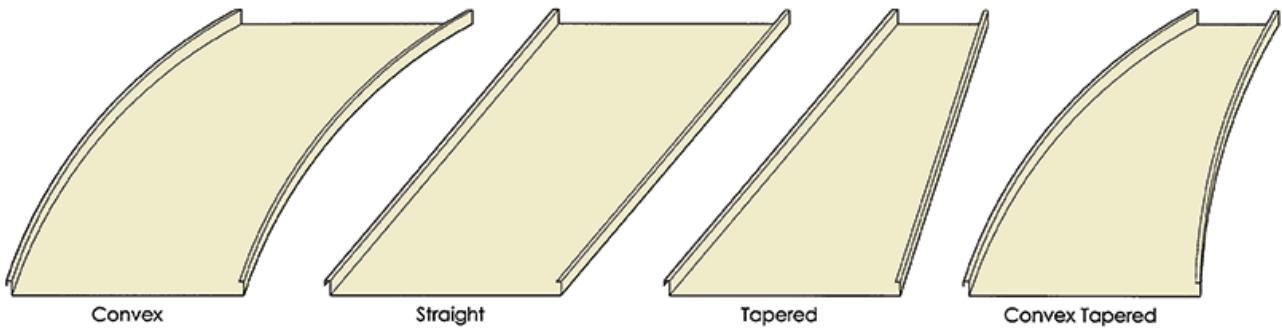
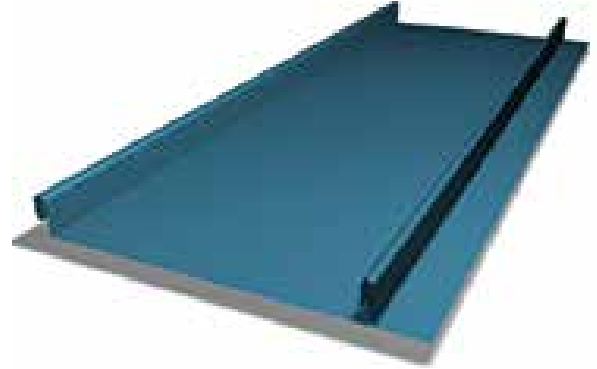

Comprising of metal trays mechanically seamed during installation, the profiles produce structurally strong and rainproof joints, by folding the panel edges to 180° or 360° to form an angled or double seam. This exclusive seaming process integrates both fixed and sliding non-penetrating clips into the seam to accommodate expansion and contraction of roof panels to allow for the most watertight seal available.

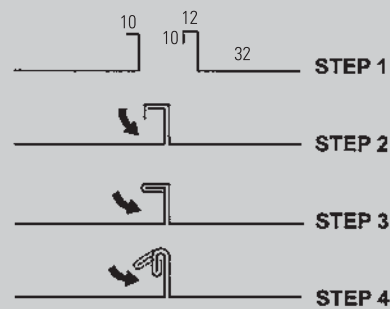

Mechanical Seaming Process
Note: Seaming process can be completed at step 3 or step 4.

PHYSICAL PROPERTIES

LYSAGHT® LOCKED SEAM®

THICKNESS

Base Metal Thickness (BMT)	0.55mm
Total Coated Thickness (TCT)	0.61mm / 0.60mm
Cover width	315mm or 515mm
Seam height	32mm

RECOMMENDED RADIUS FOR LYSAGHT® LOCKED SEAM® PROFILE

	Minimum Radius (mm)	Maximum Radius (mm)
SHEET PROFILE		
Pre-curve	800	30000
Sprung curve	30000	60000
Grade of steel	G300 (300N/mm ² yield strength)	
Coating class	AZ 200 / AZ 150	
Minimum roof pitch	3° (without end-lap) , 5° (with end-lap)	
Maximum length available	Maximum transportable length	

Note: Please consult BlueScope Lysaght Singapore for information on drag load.

LYSAGHT® LOCKED SEAM® (Standard)

	Cover Width (mm)	Seam Height (mm)	Nominal Weight (kg/m ²)	Finishes	Fastener Compatibility	Material Manufacturing Standard	Colour & Weathering Characteristics
LYSAGHT® LOCKED SEAM®	315	32	5.757	Clean COLORBOND® Steel	Zinc / Aluminium alloy	Australian Standard Substrate - AS1397 Paint Coating - AS2728 Category 3	Colour-homogenous with little colour change. Changes in colour to be based on Δ E unit of Hunterlab count
	515	32	5.295	- Ultra - XPD (PVDF paint system)			

Note: •Please consult your BlueScope Lysaght Singapore Sales Consultant for information on non-standard widths and non-standard material.

•Cover widths specified herein are applicable for non-cyclonic areas only. For cyclonic area and high wind conditions, panel cover width will be configured separately.

CONDENSATION, NOISE AND INSULATION

Insulation to meet the Noise Criteria can be incorporated into the roof system. Please consult BlueScope Lysaght Singapore for further clarification.

SUBSTRATE

LYSAGHT® LOCKED SEAM® roof profile cannot span between spaced support and therefore require panels to be laid over solid substrates, such as LYSAGHT® SPANDEK® substrate or LYSAGHT® TRIMDEK® substrate with a Coated Thickness (TCT) of 0.47mm in ZINCALUME® steel.

HEAT CONTROL

The effective method to control the heat to drape a membrane of the reflective foil lamination over the support before laying the sheeting or insulation blanket. The laminate can also provide a vapour barrier to minimise condensation. The insulation blanket is often provided for additional heat insulation to overall system.

RAIN NOISE

To reduce rain noise on metal roof sheeting, a self adhesive bitumen felt is placed underneath the roof sheeting to dampen the rain induced vibration at point of impact. This is followed by installation of a solid roof substrate such as LYSAGHT®SPANDEK®substrate or LYSAGHT®TRIMDEK®substrate. An insulation mineral wool blanket will then be placed in between the metal roof substrate and

a layer of double-sided aluminium foil. Noise will be further reduced by the loss through the mineral wool blanket to achieve a significant marked noise reduction. Note : When using an insulation mineral wool blanket, care should be taken to ensure that it is fully protected from moisture

Example: LYSAGHT® LOCKED SEAM® profile with LYSAGHT® SPANDEK® substrate

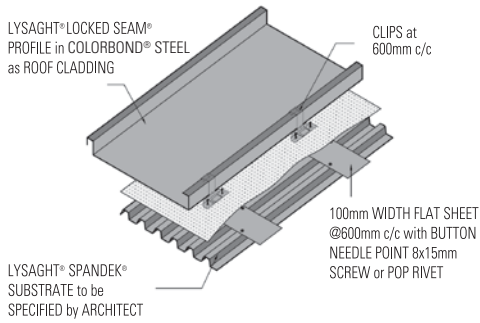

LYSAGHT® LOCKED SEAM® profile with LYSAGHT® TRIMDEK® substrate

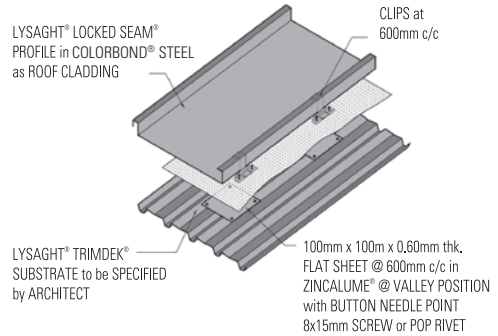

ACOUSTIC ROOF SYSTEM

As a result of laboratory measurement of airborne sound transmission loss of BlueScope Lysaght's Acoustic Roof System, PSB Corporation Singapore (Acoustic Test Laboratory) has rated the roof system tested on October 10,

2002 as having a sound transmission Class 51 (STC 51). The test was conducted in accordance with ASTM E90 – 97.

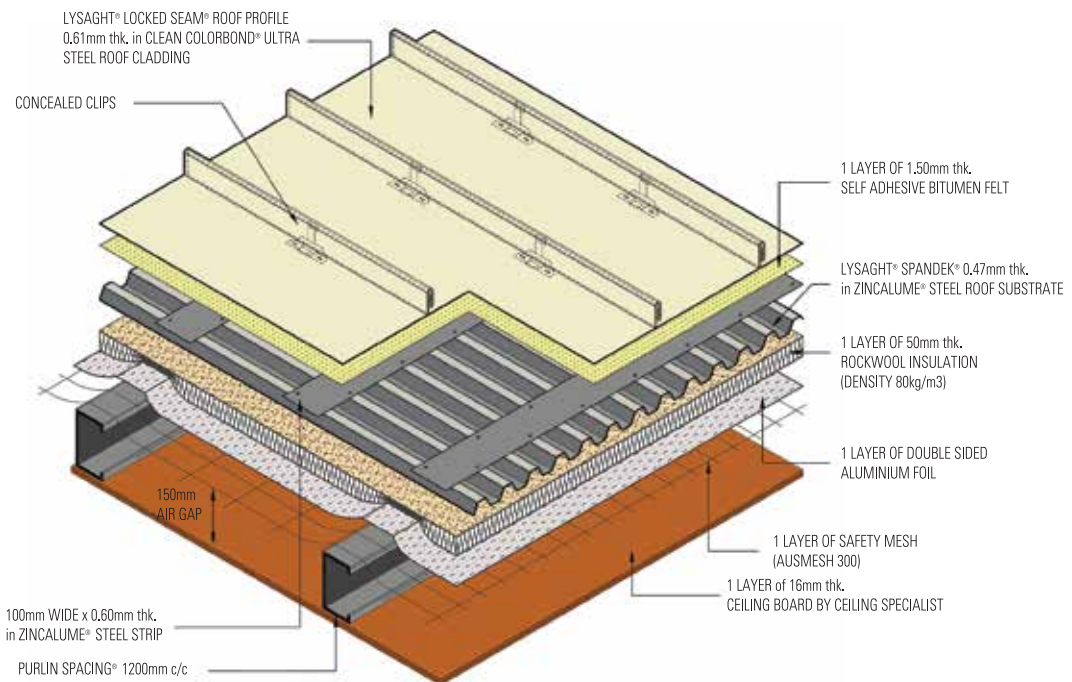

Typical Roof Built-up of LYSAGHT® LOCKED SEAM® in sound transmission class STC 51

FASTENING METHOD OF LYSAGHT® LOCKED SEAM® ROOF PROFILE

LYSAGHT® LOCKED SEAM® Roof Profile are designed to be suitable for fastening onto a solid substrate, corrugated profile or structural decking. Our proprietary concealed fixing clips from LYSAGHT® solutions are integrated into the standing seam rib. The anchorage and the method of fastening are crucial factors in the fixing of roof skin to the substructures. All forces arising from the wind pressure must be safely directed from the roof skin via all other building components into the anchorage. The suction force

applicable to a roof are influenced by the roof shape as well as height and position of the building. Peak suction will occur at the exposed roof edge and overhanging area.

The design calculation and wind load analysis of the fixing methodology has been specially designed by BlueScope Lysaght Technology Centre an verified by the Department of Civil Engineering, National University of Singapore.



FASTENING METHOD FOR HIGH WIND AND CYCLONIC LOAD

LYSAGHT® LOCKED SEAM® roof profile can be designed and configured to withstand high wind pressure and cyclonic load. The test has been carried out in accordance with: "Structural Adequacy Test under Static Pressure to ASTM E330" and "Structural Adequacy Test under BD PNAP 106 Cyclic".

Tests and simulation were conducted in a specially designed prefabricated steel chamber that is HOKLAS (Hong Kong Laboratory Accreditation Scheme) accredited with Reg. No. HOKLAS 110.

Please contact BlueScope Lysaght Singapore for details on cover width, thickness and design load application for LYSAGHT® LOCKED SEAM® roof profile.

OIL CANNING

The appearance of flatness depends on the distribution of the stresses across the surface of the metal sheet. These stresses will change as temperature changes. The ability of a metal to transfer the effect of these stresses across the surface without buckling or distorting out of plan will determine the level of "oil canning" that will occur.

"Oil canning" is a metaphorical term used to describe the tendency of flat surfaces to show variations in reflectivity. For example, a curved mirror will show a stretched and distorted image of a person standing in front of it. A metal surface too, will distort the reflection of light if minor variations in and out of a level plane exist. The appearance of flatness is very much dependent on surface reflectivity. It is also caused by mill tolerances, variations in the substrate/decking and purlin alignment. Some paint finishes and metals that have high gloss index will exhibit highly apparent distortion. The visual effects of oil canning can be exacerbated by different light as conditions and orientation. Darker colours visually to accentuate oil canning to a greater extent than the plan, lighter, more neutral colours.

There are several precautions that can be taken to reduce the oil canning effect. One is to use thicker material, because thicker metal tends to oil-can less than thinner metal. An alternative is to specify LYSAGHT® LOCKED SEAM® trays with stiffening ribs in the pan of the panels.

Oil canning is an inherent characteristic and not defect of a standing seam profile. It is therefore not a cause for panel rejection.

NOTE: Please refer to "Guidelines for Specification and Installation of LYSAGHT® Roofing and Walling Solutions" for detailed information on installation method, tips for inspection and compatibility notes.



REMINDER!

If you are working at height 2 metres and above, you must wear a safety harness with a shock absorbing twin tail lanyard attached to either a life line or an anchorage point. In addition, the use of Ausmesh 300 is recommended to assist in the prevention of falls during roof sheet laying. Contact BlueScope Lysaght Singapore for more information on Ausmesh 300.

Lakeside Primary School



Linkway at Kranji Racecourse



Residential Project



Esplande Theater by the Bay

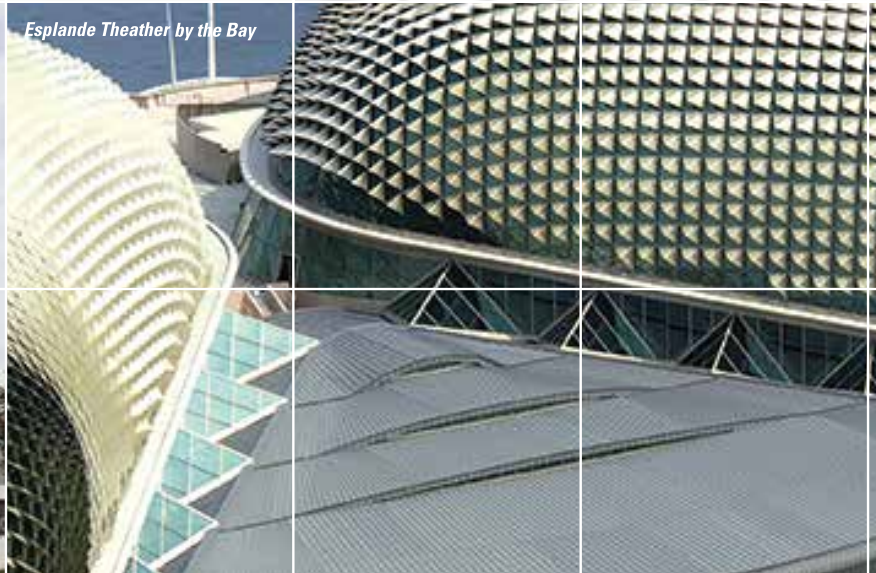

Tampines Swimming Complex





Trusted Partner for Building Systems

NS BLUESCOPE LYSAGHT SINGAPORE PTE LTD

18 BENOI SECTOR
JURONG TOWN
SINGAPORE 629851

TEL : 65-6264 1577

FAX : 65-6265 0951



DESIGN FLEXIBILITY



DURABILITY / SECURITY



HI-TECH PRODUCTION



RECYCLING



COLOUR CHOICES



THERMAL EFFICIENCY



WARRANTY

www.lysaght.com.sg
lysaght.singapore@bluescope.com

Web:

