



# LYSAGHT® TRIMDEK® Roofing and Walling Solutions



DESIGN  
FLEXIBILITY



DURABILITY /  
SECURITY



HI-TECH  
PRODUCTION



RECYCLING



COLOUR  
CHOICES



THERMAL  
EFFICIENCY



WARRANTY





# Contents

Product Information	4
Fastening Method	12
Noise & Heat Control	14
Suggested Specifications	15
Specifications for Acoustic Roof System	17
Standard Flashings/Cappings	19
Method Statement	20

# Product Information

## 1. PRODUCT PROFILE

LYSAGHT® TRIMDEK® steel cladding is one of the more economical LYSAGHT® profiles. It has excellent spanning capacity that is the greatest advantage of this profile. Roll-formed with precision from genuine High Tensile G550 ZINCALUME® steel, it is

available in a range of attractive and durable Clean COLORBOND® steel proprietary paint systems. Designed to perform at a minimum recommended roof pitch of 3°, LYSAGHT® TRIMDEK® provides a lightweight but extreme spanning capacity. With great spanning, it helps to save cost. LYSAGHT® TRIMDEK® is tested and

proven by NATA registered laboratory at BlueScope Lysaght (Research & Development) Sydney – Australia and CSIRO (Commonwealth Scientific and Industrial Research Organisation Australia), LYSAGHT® TRIMDEK® remains as one of the most economical product for the past few decades.

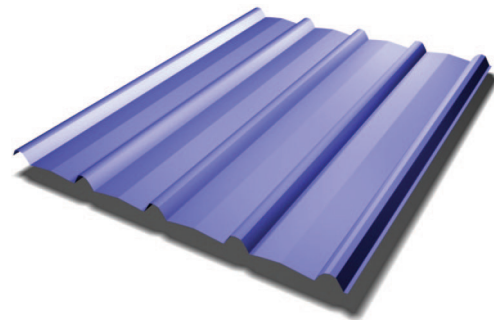
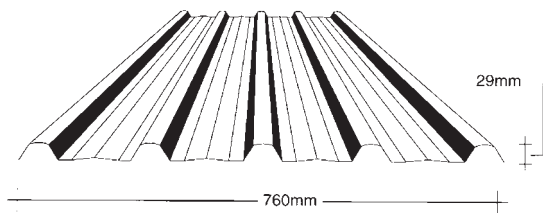

## 2. PHYSICAL PROPERTIES

Profile	LYSAGHT® TRIMDEK® (Regular / standard)	LYSAGHT® TRIMDEK® (Heavy Duty / non standard)
Steel Grade (N/mm <sup>2</sup> )	G550 ZINCALUME® steel	G550 ZINCALUME® steel
Effective Width of Coverage	760mm	760mm
Depth of Rib	29mm	29mm
Minimum Recommended Roof Pitch	3° (For sheet length without end lap) 5° (For sheet length with end lap)	3° (For sheet length without end lap) 5° (For sheet length with end lap)
Base Metal Thickness (BMT)	0.42mm	0.48mm
Total Coated Thickness (TCT)	0.47mm*	0.53mm*
Tolerances	LENGTH +0, -15mm. WIDTH +/- 2mm	
Packing	In strapped bundles of 1 tonne maximum mass	
Custom Cut Lengths	Any measurement to a maximum transportable length	

\* For Clean COLORBOND® Ultra steel 0.48 (Regular / standard), 0.54mm (Heavy Duty / non standard)

Thickness for LYSAGHT® TRIMDEK® (Regular/Standard)

Type of Finishing	BMT (mm)	Top Coat (mm)				Reverse Coat (mm)				TCT (mm)	Total Nominal Coated Thickness Including Paint (mm)
		AZ150	AZ200	Primer	Finish	AZ150	AZ200	Primer	Finish		
ZINCALUME® steel	0.42	0.025	-	-	-	0.025	-	-	-	0.47	-
Clean COLORBOND® steel	0.42	0.025	-	0.005	0.020	0.025	-	0.005	0.005	0.47	0.505
Clean COLORBOND® XPD steel	0.42	0.025	-	0.005	0.020	0.025	-	0.005	0.005	0.47	0.505
Clean COLORBOND® XPD Pearlescent steel	0.42	0.025	-	0.005	0.020	0.025	-	0.005	0.005	0.47	0.505
Clean COLORBOND® Ultra steel	0.42	-	0.030	0.005	0.020	-	0.030	0.005	0.010	0.48	0.520

BMT: Base Metal Thickness, TCT: Total Coated Thickness  
 AZ150: Coating Mass of 150 grams/m<sup>2</sup> on both side (55% Aluminium, 43.5 % Zinc and 1.5% Silicon)  
 AZ200: Coating Mass of 200 grams/m<sup>2</sup> on both side (55% Aluminium, 43.5 % Zinc and 1.5% Silicon)

Mass & Coverage

Finishes	Mass per Unit Area (kg/m <sup>2</sup> )		Mass per Unit Length (kg/m)		Coverage (m <sup>2</sup> /tonne)	
	Regular	Heavy Duty	Regular	Heavy Duty	Regular	Heavy Duty
ZINCALUME® steel (0.47mm)	4.288	4.871	3.259	3.702	223.202	205.310
Clean COLORBOND® steel (0.505mm)	4.362	4.945	3.315	3.758	229.235	202.229
Clean COLORBOND® XPD steel (0.505mm)	4.362	4.945	3.315	3.758	229.235	202.229
Clean COLORBOND® XPD Pearlescent steel (0.505mm)	4.362	4.945	3.315	3.758	229.235	202.229
Clean COLORBOND® Ultra steel (0.520mm)	4.424	5.007	3.362	3.805	226.031	199.731

### 3. PRODUCT BENEFITS

Like other products in the LYSAGHT® range, LYSAGHT® TRIMDEK® presents a list of long term benefits and values to customers:-

- ✓ Economical Profile
- ✓ Tested and proven by NATA registered laboratory in LYSAGHT® TECHNOLOGY (Chester Hill, Sydney – Australia)
- ✓ Tested by CSIRO (Commonwealth Scientific and Industrial Research Organisation – Australia)
- ✓ Conforms to International Building Codes and Standards
- ✓ Manufactured under strict processes governed by ISO9001:2000 (Quality Management System) and ISO14001 (Environment Management System)
- ✓ Excellent Wind Resistance
- ✓ Excellent Spanning Capacity and light weight
- ✓ Superior against severe rainfall intensity
- ✓ First class resistance against Corrosion, Discolouration and Tropical Dirt Staining
- ✓ Certified Class 'O' by Malaysian Fire & Rescue Department
- ✓ Requires no or minimal maintenance
- ✓ All weather performance
- ✓ Genuine LYSAGHT® Material Warranty
- ✓ Genuine LYSAGHT® Product Certification

### 4. DESIGN CRITERIAS

#### SUPPORT SPACINGS NON-CYCLONIC AREAS

The maximum support spacings shown in Table 1 are based on testing in accordance with AS1562 - 1992, "Design and Installation of Sheet Roof and Wall Cladding - Part 1: Metal" and AS4040.1 - 1992 "Methods of Testing Sheet Roof and Cladding Method 1: Resistance to Concentrated Loads". These roof support spacings are

the maximum recommended for adequate performance of the roof cladding under foot traffic loading. The wall spacings are the maximum recommended for buildings up to 10m high in Region B Terrain Category 3 conditions ( $V_s=38\text{m/s}$  &  $V_u=60\text{m/s}$  using  $C_{pe}=0.65$ ,  $C_{pi}=0.2$  &  $KI=2.0$ ).

These spacings may be reduced by the Serviceability and Strength Limit States for the particular project under consideration.

Table 1: Maximum Allowable Support Spacings – NON CYCLONIC AREAS

TYPE OF SPAN		LYSAGHT® TRIMDEK® (Regular / standard)	LYSAGHT® TRIMDEK® (Heavy Duty / non standard)
		0.42mm BMT	0.48mm BMT*
ROOF	Single Span	1100mm	1600mm
	End Span	1300mm	1850mm
	Internal Span	1900mm	2600mm
	Unstiffened Overhang	150mm	200mm
WALL	Single Span	2100mm	2100mm
	End Span	2900mm	3000mm
	Internal Span	2800mm	3000mm
	Overhang	150mm	200mm

\* Minimum order is required for 0.48mm BMT, please contact BlueScope Lysaght office

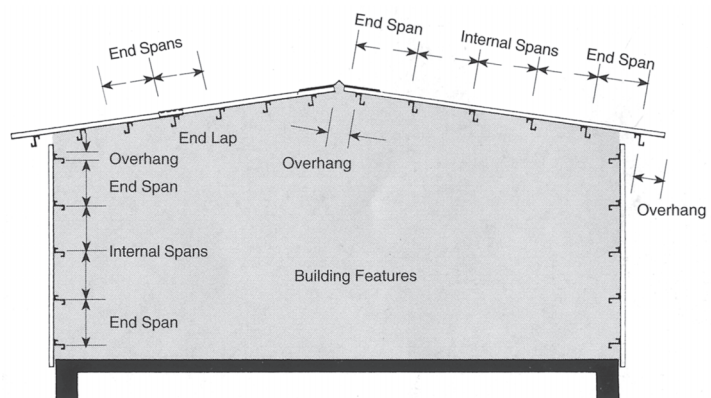

**LIMIT STATE WIND PRESSURES  
(NON-CYCLONIC AREAS)**

The wind pressure capacities are based on tests conducted at NATA registered testing laboratory at LYSAGHT® TECHNOLOGY in Sydney, Australia. Testing was conducted in accordance with AS1562.1 - 1992, "Design and Installation of Sheet Roof and Wall Cladding", and AS4040.2 -

1992, "Resistance to Wind Pressure for Non-Cyclonic Regions". The table for wind pressure capacities provides pressure versus span graphs for Serviceability and Strength Limit State Design. Serviceability Limit State is based on a deflection limit of: (span/120) + (P/30), where P is the maximum fastener pitch. The pressure capacities for Strength Limit State have been determined by testing the cladding to

failure (ultimate capacity). These pressures are applicable when the cladding is fixed to minimum material thickness of 1.0mm. To obtain the design capacity of the sheeting, a capacity reduction factor of 0.90 should be applied. A non-cyclonic area is defined as one in which a tropical cyclone is unlikely to occur in accordance with AS1170.2-1989, "SAA Loading Code, Part 2: Wind Loads".

**Table 2: LYSAGHT® TRIMDEK® WIND CAPACITIES (kPa) – Limit State Format (Non-Cyclonic)**

LYSAGHT® TRIMDEK®											
Base Metal Thickness	Type of Span	Limit State	Span (mm)								
			600	900	1200	1500	1800	2100	2400	2700	3000
0.42mm	Single	Serviceability	4.98	3.91	2.83	1.87	1.16	0.75	0.53	-	-
		Strength	11.40	9.30	7.15	5.30	4.00	3.75	3.10	-	-
	End	Serviceability	4.18	3.63	3.08	2.55	2.06	1.62	1.22	0.85	0.50
		Strength	7.05	6.50	5.90	5.35	4.80	4.20	3.65	3.05	2.50
	Internal	Serviceability	5.05	4.18	3.42	2.83	2.36	1.94	1.56	1.23	0.97
		Strength	10.50	8.85	7.25	5.85	4.80	4.03	3.65	3.40	3.20
0.48mm	Single	Serviceability	7.27	5.06	3.34	2.06	1.15	0.71	0.50	0.42	-
		Strength	15.05	12.90	10.70	8.60	6.80	5.25	4.00	2.95	-
	End	Serviceability	6.29	5.13	3.96	2.93	2.13	1.54	1.12	0.82	0.58
		Strength	10.40	8.90	7.30	5.90	4.80	4.10	3.60	3.25	3.05
	Internal	Serviceability	7.37	5.96	4.66	3.54	2.72	2.22	1.92	1.64	1.38
		Strength	11.00	9.50	8.15	6.95	6.00	5.30	4.80	4.30	3.85

\* Minimum order is required for 0.48mm BMT, please contact BlueScope Lysaght office



PTC Warehouse, Singapore

## SUPPORT SPACINGS CYCLONIC AREAS

**Table 3: Maximum Allowable Support Spacing - LYSAGHT® TRIMDEK® for Cyclonic Regions**

LYSAGHT® TRIMDEK®									
BASE METAL THICKNESS	TYPE OF SPAN	WITHOUT CYCLONIC WASHERS				WITH CYCLONIC WASHERS			
		W41C (147.6km/hour) 2.017kPa	W50C (180.0km/hour) 3.000kPa	W60C (216.0km/hour) 4.320kPa	W70C (252.0km/hour) 5.860kPa	W41C 5.860kPa 2.017kPa	W50C (180.0km/hour) 3.000kPa	W60C (216.0km/hour) 4.320kPa	W70C (252.0km/hour) 5.860kPa
0.42mm	End	1000	855	615	500	1000	1000	1000	840
	Internal	1505	1120	795	580	1700	1475	1290	1045
0.48mm*	End	1385	925	655	520	1620	1340	1090	900
	Internal	2020	1160	825	595	2060	1690	1395	1135

Notes on Table 3:

1. Fastening procedures and methods to comply with the strict recommendations of BlueScope Lysaght
2. Parameters for determining the cyclonic design wind pressures are:  
 $K = 1.5$  (low pressure zone local factor);  $C_{pi} = +0.65$ ;  $C_{pe} = -0.90$   
 $V_z$  = Design fast wind speed (e.g. W41C = 41m/s)  
 The design wind pressure is obtained from:  $P_d = (C_{pi} - K_{cpe}) V_{z^2} \times 0.6 \times 10^{-3}$  [kPa].
3. Some support spacings are governed by walk-on requirements.
4. Specification of support must be of high tensile steel, with a minimum Base Metal Thickness of 1.00mm and minimum yield stress of 550MPa (for more info, please consult BlueScope Lysaght).

\* Minimum order is required for 0.48mm BMT, please contact BlueScope Lysaght office

**Table 4a): LYSAGHT® TRIMDEK® (Allowable Wind Pressure kPa) for Cyclonic Areas**

SPAN	ROOFING OR WALLING APPLICATIONS 0.42mm BMT						WALLING APPLICATIONS ONLY 0.42mm BMT		
	CREST FASTENED WITHOUT CYCLONE WASHERS			CREST FASTENED WITH CYCLONE WASHERS			VALLEY FASTENED		
	Single	End	Internal	Single	End	Internal	Single	End	Internal
600	8.55	4.40	5.50	8.55	8.00	10.00	8.55	4.40	5.50
900	3.91	2.93	3.67	5.45	5.33	6.67	3.91	2.93	3.67
1200	2.20	2.20	2.75	3.07	3.47	5.00	2.20	2.20	2.75
1500	1.41	1.41	2.03	1.84	1.78	2.84	1.41	1.41	2.03
1800	0.89	0.80	1.37	0.89	0.80	1.75	0.89	0.80	1.37
2100	0.48	0.50	1.01	0.48	0.50	1.10	0.48	0.50	1.01



**Table 4b): LYSAGHT® TRIMDEK® (Allowable Wind Pressure kPa) for Cyclonic Areas**

SPAN	ROOFING OR WALLING APPLICATIONS 0.48mm BMT						WALLING APPLICATIONS ONLY 0.48mm BMT		
	CREST FASTENED WITHOUT CYCLONE WASHERS			CREST FASTENED WITH CYCLONE WASHERS			VALLEY FASTENED		
	Single	End	Internal	Single	End	Internal	Single	End	Internal
600	9.20	4.60	5.75	9.37	8.76	10.95	9.37	5.00	6.25
900	5.00	3.07	3.83	6.25	5.84	7.30	5.00	3.33	4.17
1200	2.81	2.30	2.87	4.05	3.51	5.47	2.81	2.50	3.12
1500	1.80	1.84	2.50	2.59	2.44	3.74	1.80	2.00	2.60
1800	1.25	1.41	2.25	1.25	1.41	2.60	1.25	1.41	2.25
2100	0.79	0.89	1.93	0.79	0.89	1.93	0.79	0.89	1.93
2400	0.53	0.60	1.30	0.53	0.60	1.30	0.53	0.60	1.30

Note on Table 4:

- (1) The performance of LYSAGHT® TRIMDEK® has been established using cyclic test criteria as specified in NBTC Technical Record 440. The allowable spans in the quick selection tables were obtained by linear interpolation of the design pressures established from those tests and conservative applications of the local pressure factors. These criteria are considered unnecessarily restrictive for use on larger or more complex buildings of the type normally designed by the architect and engineer.
- (2) Racking strength provided by the cladding has not been tested and should not be allowed for in the design.
- (3) Spans calculated using the Allowable Wind Pressure Tables may variously be governed by fastener load limits, moment induced buckling of the sheeting, or deflection. The resultant pressures are calculated using AS1170 Part 2, 1989 SAA Loading Code – Wind Forces.
- (4) The various conditions which affect the design wind speeds, such as geographic location, terrain category etc, are to be taken from AS1170 Part 2, 1989 SAA Loading Code – Wind Forces. The resulting four standardised cyclone wind speeds, 41, 50, 60 and 70m/s (designated as W41C, W50C, W60C and W70C respectively) are used in selection of batten spacing for each of our cladding, most of which vary in their spanning capacity.

\* Minimum order is required for 0.48mm BMT, please contact BlueScope Lysaght office



Sepak Takraw &  
Silat Federation @  
Bedok Sport Complex,  
Singapore

### Crimp Curved Convex Roof

Crimp curved LYSAGHT® TRIMDEK® steel cladding was designed to provide versatility and creativity to bring new and refreshing designs to commercial, industrial and domestic buildings. The combination of curves and contours in convex shapes with flats and angles in LYSAGHT® TRIMDEK® have produced many aesthetically pleasing buildings.

This design freedom has resulted in significant cost savings in construction, mainly due to:-

- Less supporting framework required for fascias, parapets and roofs.
- Simplified and reduced work involved in installation of fascia cladding.
- Reduction or elimination of many flashings and cappings.
- Less cladding material required to cover a given curve.

### SUPPORT SPACINGS FOR CRIMP CURVED LYSAGHT® TRIMDEK® (NON CYCLONIC AREAS)

For the Straight Portion of Crimp Curved LYSAGHT® TRIMDEK®

- Maximum allowable spacings for the straight portion of Crimp Curved LYSAGHT® TRIMDEK® should follow the recommendations given in Table 1.
- End spans refer to the spacing between the first and second supports from any free end of a sheet, except where that end of the sheet is crimp curved.
- The spacing between supports either side of an end lap should be as recommended for end spans (refer to Table 1).

For the Crimp Curved Portion of Crimp Curved LYSAGHT® TRIMDEK®

These will depend on the radius of curvature but the following guidelines are recommended:-

- For sheets curved to a radius of curvature not more than 3000mm, supports should be placed at centres not greater than 2100mm measuring around the arc of the curve.
- Where a curve of small included angle occurs (up to approximately 15 degree, for example at a ridge), support spacing should not exceed 1200mm.

Note: For support spacings for Cyclonic Areas, please refer to Table 3 and Table 4.

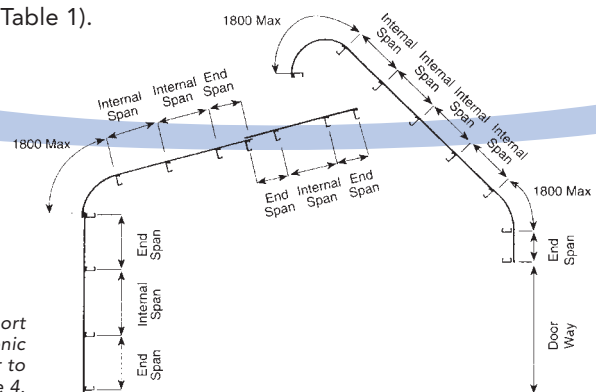

### REQUIREMENTS FOR CRIMP CURVED LYSAGHT® TRIMDEK®

- Minimum radius of curvature for convex is 450mm and 550mm for concave to underside or pan of sheet, minimum straight length of sheet at one end of a curve is 180mm.
- Maximum length of sheet that can be crimp curved for ridge application is approximately 12000mm. The curve can either be convex or concave.
- The sheet can be crimp curved to three quarters of a full circle but to facilitate side lapping, semi circle maximum is recommended.

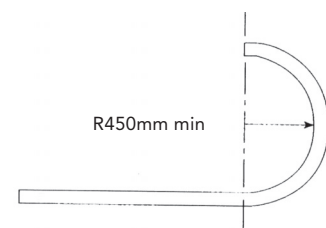
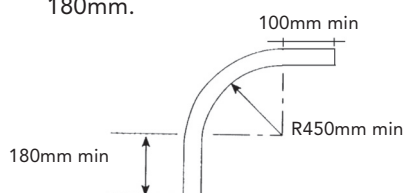

- When both ends are crimp curved, the maximum recommended straight distance between the two curves should be 6000mm.

- For length exceeding 12000mm, please consult BlueScope Lysaght
- For easy transportation and maximum protection for the crimp

curved sheets, the maximum height and length of the sheeting should be 2000mm and 11300mm respectively.

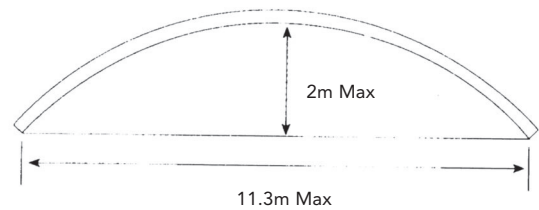
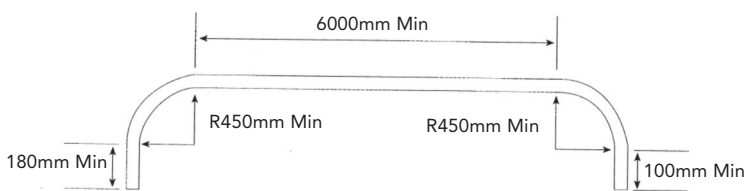

\*\* Alternatively, for crimp-less profile, please ask for our LYSAGHT® SELECT SEAM®, LYSAGHT® LOCKED SEAM™, LYSAGHT CUSTOM ORB® and LYSAGHT CUSTOM BLUE ORB®

#### RAINWATER RUN-OFF FOR LYSAGHT® TRIMDEK®

The drainage or run-off capacity of roof sheeting is another limitation on the total length of a sheet run that must be considered in roof design and construction. As a guide, Table 5 lists

the maximum recommended length of roof run for LYSAGHT® TRIMDEK® at the roof slopes and rainfall intensities shown. These are based on CSIRO (Commonwealth Scientific and Industrial Research Organisation – Australia) and BlueScope Lysaght calculation of the behaviour of

LYSAGHT® roofing profiles under peak rainfall conditions.

The roof run is the total length of roof sheeting draining rainwater in one direction including any end laps, expansion joints or steps that may be present in the roof.

**Table 5: Maximum Roof Run (in metres) for roof slopes and rainfall intensities**

LYSAGHT® Sheet Profile	Rainfall Intensity (mm/hour)	Roof Slope			
		1 in 20 (3°)	1 in 12 (5°)	1 in 7.5 (7.5°)	1 in 6 (10°)
LYSAGHT® TRIMDEK®	200	105	123	139	152
	250	84	98	111	121
	300	70	82	92	101
	400	52	61	69	76

# Fastening Method

## The Pierce-Fixing Concept

Pierce-fixing is the method of fixing sheets using fasteners which pass through the sheet. This method is different from concealed-fixing.

The screws can be placed through the crests or in the valleys. LYSAGHT® TRIMDEK® steel roof cladding must be crest fixed to support. However wall cladding can be either crested or valley fixed.

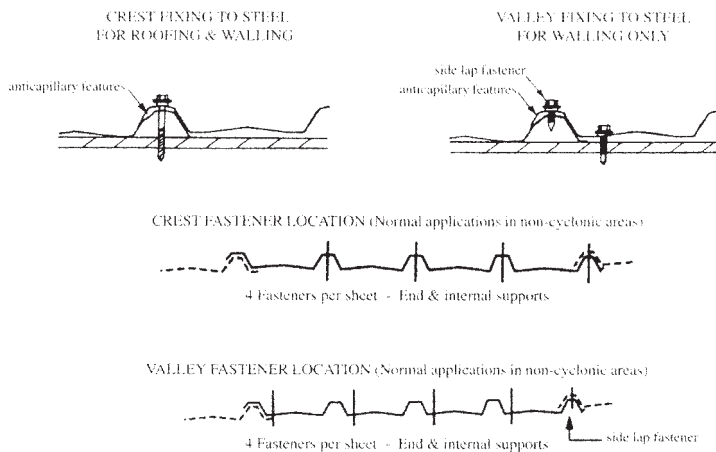

## RECOMMENDED FASTENERS

	Non-Cyclonic		Cyclonic	
	Directly to support	With Insulation Blanket*	Directly to support	With Insulation Blanket*
<b>Steel Supports</b>				
<b>Thickness</b> Up to 4.5 mm	No. 12-14 x 55 mm Hex head self drilling and tapping screw with bonded washer	Increase to min. 65 mm long screw	No. 14-14 x 55 mm Hex head self drilling screw with cyclonic assembly	Increase to min. 65 mm long screw
Exceed 4.5 m	Tek 5 No. 12-24 x 68 mm Hex head self drilling and tapping screw with bonded washer	Tek 5 No. 12-24 x 68 mm Hex head self drilling and tapping screw with bonded washer	As above but with predrilled holes	As above but with predrilled holes
<b>Timber Supports</b>				
<b>Grade</b> Hardwood	No. 12-11 x 65 mm Hex head Type 17 self drilling screw with bonded washer	No. 14-10 x 75 mm Hex head Type 17 self drilling screw with bonded washer	No. 14-11 x 65 mm Hex head Type 17 self drilling screw with cyclonic assembly	No. 14-10 x 75 mm Hex head Type 17 self drilling screw with cyclonic assembly
Softwood	No. 14-10 x 75 mm Hex head Type 17 self drilling screw with bonded washer	No change	No. 14-10 x 75 mm Hex head Type 17 self drilling screw with cyclonic washer	No change

### Crest – Fixing Application:

Fastener Description	Max. attachment (mm)	Drilling capacity (mm)
CTEKS 12-14x50 HGS	25 – 36	6.5
CTEKS 12-14x55 HGS	31 - 40	6.5
CTEKS 12-14x68 HGS	39 - 53	6.5

### Mechanical Properties:

Single shear strength	8 800 N
Axial tensile strength	15 300 N
Torsional strength	13.2 Nm
<i>Tested on "Undriven" screw</i>	

### Identification of Fastener

The format of the number code is:

**12 - 14 x 55**

Screw gauge (Thread outside diameter)	Thread pitch (Thread per inch)	Overall length of the screw measured from under the head (mm)
--	--------------------------------------	---



### Ultimate Average Pullout Data:

Base thickness*	G450 steel
1.0 mm	-
1.2 mm	3 100 N
1.5 mm	4 200 N
1.9 mm	5 500 N
2.4 mm	7 300 N
3.0 mm	9 800 N

*Tested under laboratory conditions*

*\* Please contact BlueScope Lysaght office for verification.*

### Product Features:



- Forged drill point
- ShankGuard
- HiGrip
- Unthreaded shank
- Full range of colour heads
- Non-conductive EPDM washer
- Climaseal proven corrosion protection
- Drills purlins up to 6.5 mm thick

### Product Specifications :

Diameter	12 Gauge (5.43 mm thread diameter )
Thread Form	14 threads per inch
Drive	5/16" external hexagonal socket
Drill Point	P4.5 / 6.5
Material	AISI 1022 Heat treated carbon steel

ACJC, Singapore



# Noise & Heat Control

## Rain Noise

To reduce rain noise on metal roof sheeting, an insulation mineral wool blanket can be placed in between 2 metal roof cladding. Anyway, as long as the insulation blanket is held hard against the underside of the roof sheeting this will dampens the rain induced vibration at point of impact and a marked noise reduction is achieved. Otherwise, noise will only be reduced by transmission loss through the mineral wool blanket. (Note: When using an insulation mineral wool blanket, care should be taken to ensure that it is fully protected from moisture).

## Heat Control

The effective method to control the heat is to drape a membrane of the reflective foil laminate over the supports before laying the sheeting or insulation blanket. The laminate can also provide a vapour barrier to minimise condensation. The insulation blanket is often provide the additional heat insulation to overall system.

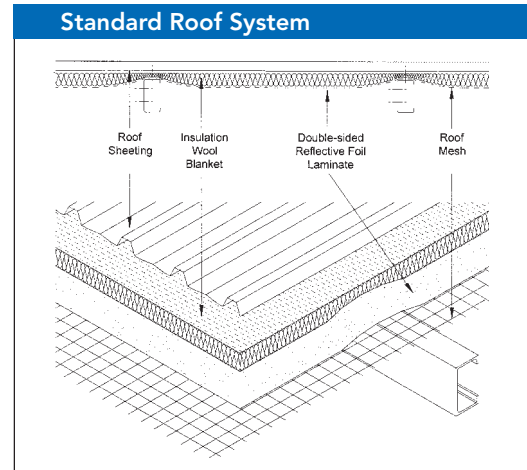

## Acoustic roof system (Please see page 17 for specification)

As a result of laboratory measurement of airborne sound transmission loss of BlueScope Lysaght Acoustic Roof System, PSB Corporation (testing group) had rated the roof system tested on October 10, 2002 as having a sound transmission class 51 (STC 51). The test was conducted in accordance with ASTM E90 – 97.

- *Sound Transmission Class (STC) 51 Roof Build-Up: Testing was carried out with the ceiling boards*

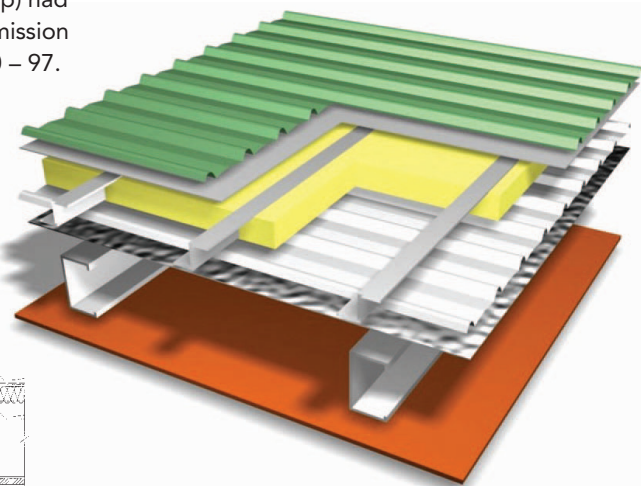
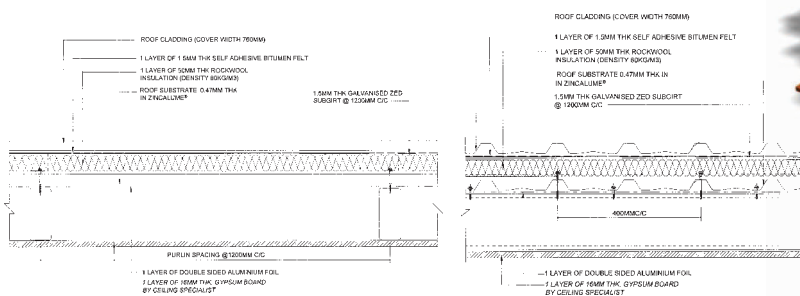

# Suggested Specifications

## Suggested Specifications for LYSAGHT® TRIMDEK®

1) Atmospheric Condition: **benign exposure in marine environment (>1000m from breaking surf)**

LYSAGHT® TRIMDEK® 0.47mm TCT in Clean COLORBOND® steel (G550-AZ150)

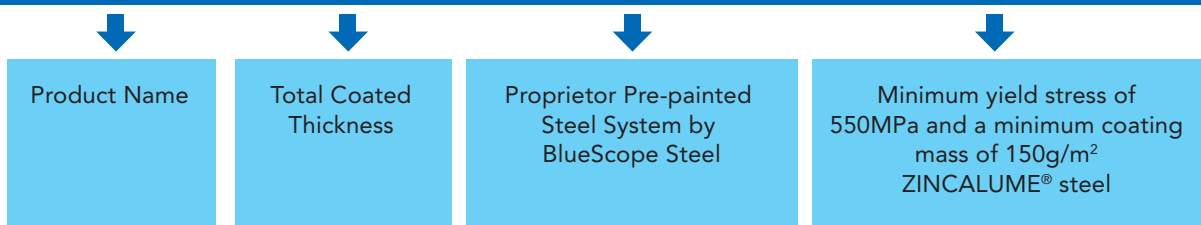

*Note: No minimum quantity requires for material order*

2) Atmospheric Condition: **benign exposure in marine environment (>1000m from breaking surf)**

LYSAGHT® TRIMDEK®, 0.47mm TCT in Clean COLORBOND® XPD steel (G550-AZ150)

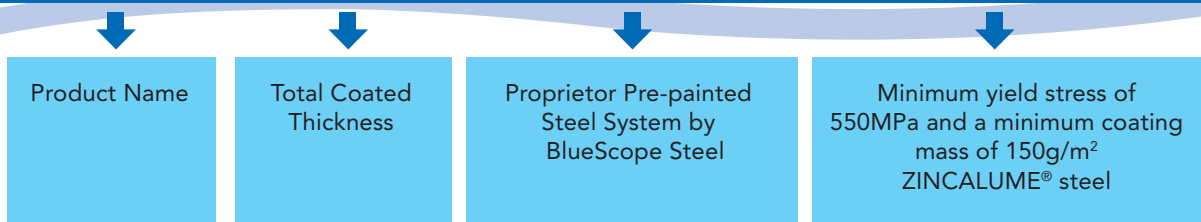

*Note: Minimum quantity requires for material order.  
Please contact our office in your respective area (country)*

3) Atmospheric Condition: **benign exposure in marine environment (>1000m from breaking surf)**

LYSAGHT® TRIMDEK®, 0.47mm TCT in Clean COLORBOND® XPD Pearlescent steel (G550 AZ150)

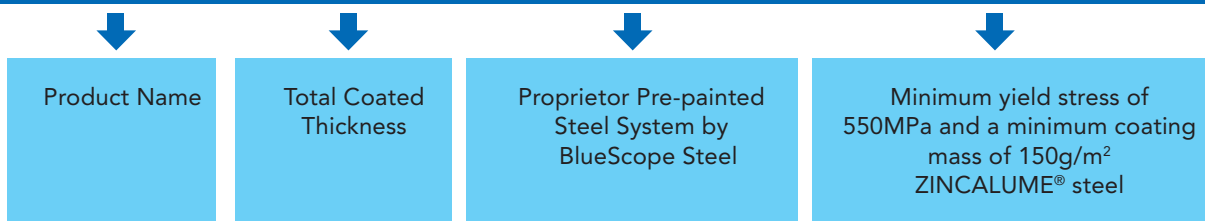

*Note: Minimum quantity requires for material order.  
Please contact our office in your respective area (country)*

4) Atmospheric Condition: severe marine environment (100m – 200m from breaking surf, <50m from calm water)

LYSAGHT® TRIMDEK®, 0.48mm TCT in Clean COLORBOND® Ultra steel (G550-AZ200)

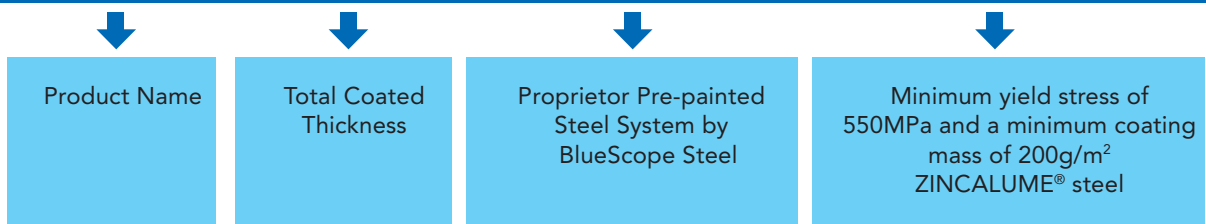

Note: Minimum quantity requires for material order.  
Please contact our office in your respective area (country)



Sepak Takraw & Silat Federation @ Bedok Sport Complex, Singapore



# General Specifications for Acoustic Roof System

## A. ROOF PROFILE

The profiled steel roof cladding shall have an effective coverage width of 760mm, with a nominal rib height and width of 29mm and 60mm respectively. The ribs are spaced at 190mm centre to centre, and with anti-capillary side-lap feature. The steel roof cladding shall be crest fastened using recommended Class 3 (conforming to AS3566 to Class 3) hexagon-head self-drilling zinc-coated fasteners.

The steel roof cladding shall comply to 5 basic International Building Codes and Standards: (1) AS1562 – 1992 (Design and Installation of Sheet Roof and Wall Cladding – Part I), (2) AS4040.1 – 1992 (Methods of Testing Sheet Roof and Wall Cladding Method I: Resistance to Concentrated Loads), (3) AS4040.2 – 1992 (Resistance to Wind Pressure for Non-Cyclonic Regions), AS4055 – 1992 (Wind Load for Housing – Cyclonic and Non-Cyclonic Regions and (4) AS1170.2 – 1989 (SAA Loading Code, Part 2: Wind Loads). In addition to that, the steel roof cladding shall also certified Class 'O' by Malaysian Fire and Rescue Department or complying to AS1530 and AS2728 (Pre-painted Organic Film / Metal Laminate Products), and shall conform to AS1580 (ASTM Test Method B117) as well as AS2105 (Taber Abrasion Resistance).

The steel roof cladding shall have a minimum Base Metal Thickness (BMT) of 0.42mm, roll-formed and manufactured from high tensile steel with a minimum yield strength of 550MPa and minimum coating mass of 150g/m<sup>2</sup> (55% aluminium, 43.5%

zinc and 1.5% silicon) or\* coating mass of 200g/m<sup>2</sup> for cladding installed in severe marine environment (conforming to AS1397 – 2001 & MS1196).

*\*choose one whichever applicable*

## B. FLASHINGS & OTHERS

Flashings, cappings, trims and rainwater goods shall be manufactured from the same material as the steel roof cladding to achieve material compatibility. Material Warranty against Corrosion, Discolouration and Tropical Dirt Staining to be provided by manufacturer after completion of jobs, installation procedures and fixing methods to strictly follow the standards and recommendations of the Manufacturer.

## C. OPTION FOR PRE-PAINTED STEEL

*(choose one whichever applicable)*

Coated sheet shall be factory coiled painted and oven-baked to AS2728 (Prepainted organic film/ metal laminate products)

### 1) Clean COLORBOND® Steel:

Recommended for benign exposure in marine environment (>1000m from breaking surf)

Top coat : Custom formulated polyester paint system of 20µm over 5µm universal corrosion inhibitive epoxy primer

Reverse coat : Custom formulated Shadow Grey. Wash coat of 5 µm over 5 µm of corrosion inhibitive epoxy primer

### 2) Clean COLORBOND® XPD Steel

Recommended for benign exposure in marine environment (>1000m from breaking surf)

Top coat : PVF2 of 20µm over 5µm corrosion inhibitive epoxy primer

Reverse coat : Snowgum Green wash coat of 5 µm over 5 µm of corrosion inhibitive epoxy primer

### 3) Clean COLORBOND® XPD Pearlescent Steel

Recommended for benign exposure in marine environment (>1000m from breaking surf)

Top coat : PVF2 of 20µm over 5µm corrosion inhibitive epoxy primer

Reverse coat : Snowgum Green wash coat of 5 µm over 5 µm of corrosion inhibitive epoxy primer

### 4) Clean COLORBOND® Ultra Steel

Recommended for severe marine environment (100m – 200m from breaking surf, <50m from calm water)

Top coat : Custom formulated system of 20µm over 5µm of custom formulated corrosion inhibitive epoxy primer

Reverse coat : Custom formulated Polyester system in standard Bass Grey of 10 µm over 5 µm of custom formulated corrosion inhibitive epoxy primer

## D. SUBSTRATE

The substrate shall be 0.47mm thick corrugated profile with a cover width of 760mm. Nominal rib height and width of 29mm and 60mm respectively. The ribs are spaced at 190mm center to center and with anti-capillary side-lap feature.

**E. SUB-GIRT**

1.5mm thick galvanized Zed girt section shall be installed over the substrate to accommodate sound insulation material (also as spacer between substrate and metal roof cladding).

**F. MINERAL WOOL INSULATION**

The sound insulation material is

mineral wool as indicated with 80kg/m<sup>3</sup> density, to a 50mm thickness. The thermal conductivity of insulation should be 0.033 w/mK at 200C (0.235 BTU in/ft<sup>2</sup>h 0F at 680F) and must comply with Australian standard 1530: Part 3 – 1976

**G. RADIANT & VAPOUR BARRIER**

The solar radiant barrier shall consist

of a tough high density polyethylene core reinforcement and 2 pressure laminated aluminium & metalised film (on bothside)

The centre core shall be of high tensile strength to enable the radiant barrier to be tear-proof and be able to support itself.

*Punggol CC, Singapore*

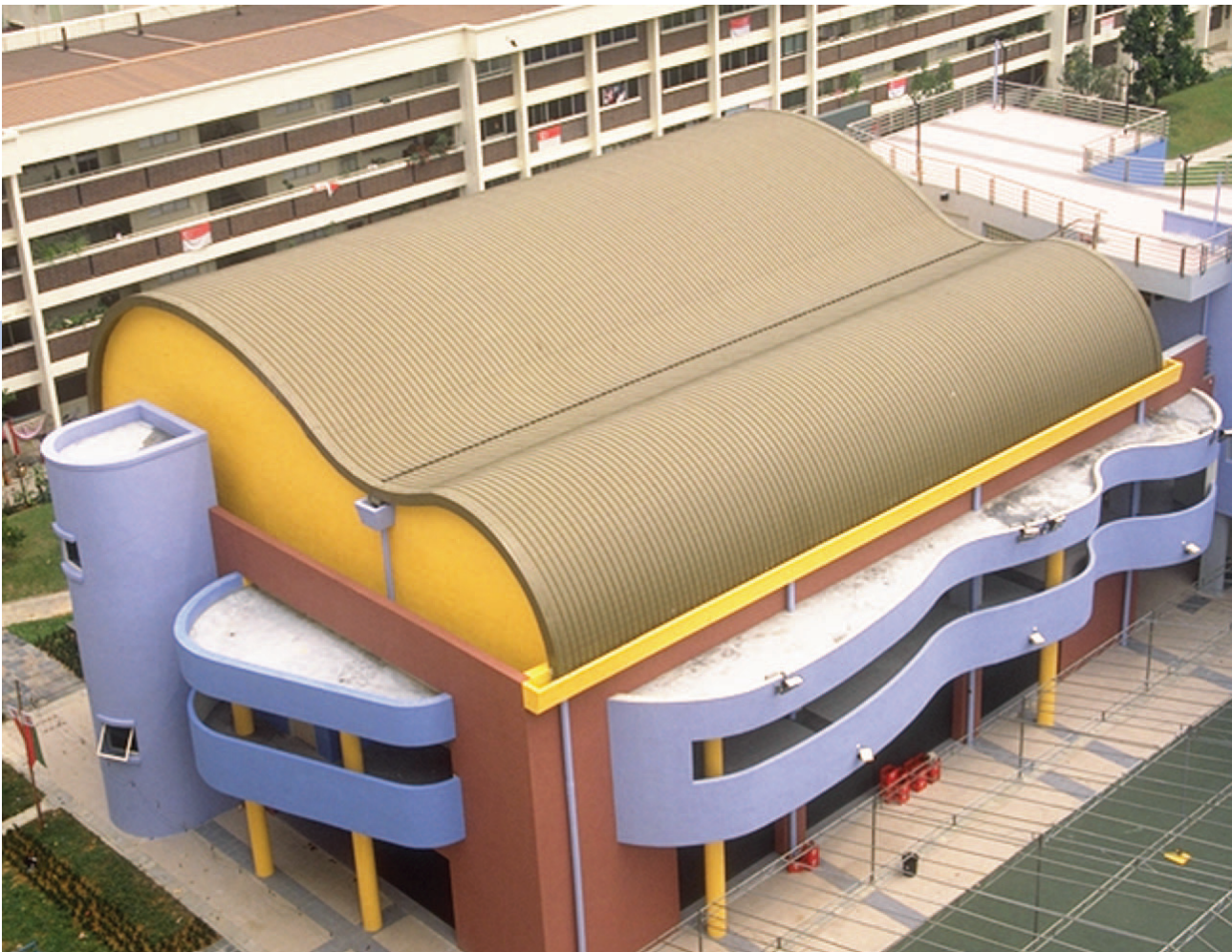

# Some Standard Flashings/Cappings

## Apron & Cover Flashings

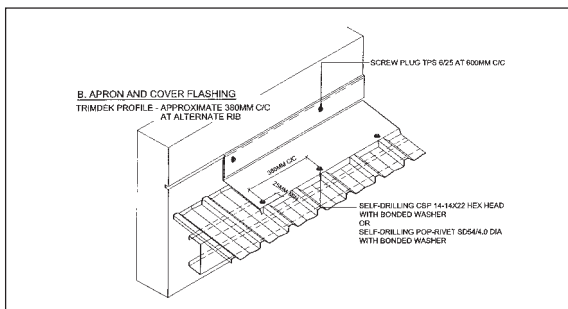

## Crimp curved longitudinal fascia capping

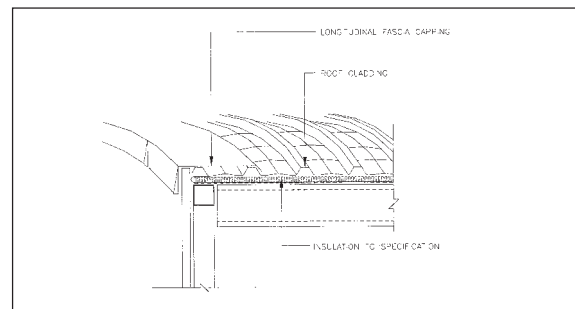

## Roof Penetration

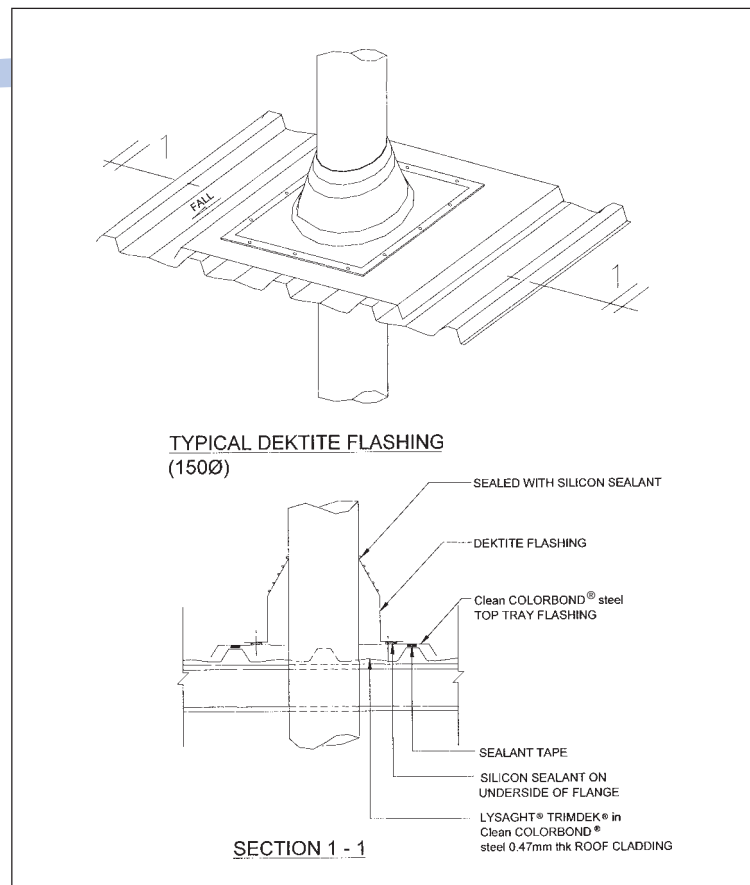

# Method Statement

## 1. GENERAL PREPARATION

### Delivery

Always check the material upon delivery. Check for damage and check material quantities against the delivery order. Note any damage or shortage at the time of delivery.

### Handling

- Handling panel bundles and individual panels with care to avoid damages that can result from buckling and or bending of panels.
  - To lift the sheet bundles with crane directly from the delivery truck onto the roof frame for large building projects.
  - For long length sheets the use of spreader bar and approved sling is recommended.
  - For small to medium size projects, without mechanical handling facilities, sheets can

be unloaded by hand and passed up to the roof at a time. For personal safety and to preserve the surface finish, sheets should be handled wearing clean dry gloves

- Do not slide sheets over the rough surfaces or over each other and do not drag tools etc over sheets.

### Care & Storage Prior to Installation

- Store the panels and other materials in a dry, well-ventilated area and away from traffic. Elevate one end of the bundles so that any moisture that may have accumulated during transportation can run off.
- Be sure that air can be circulated freely around the bundles to avoid build-up of moisture.
- Never store the material in direct contact with the ground.

### Walking on the roof

- Wear clean non-marking, soft-soled shoes when walking on the panels to avoid shoe marks on damage to the finish.
- Generally keep the load evenly distributed over both feet and not concentrate load on the heel or toe.
- When walking on roof sheeting:
  - Walk over or close to the roofing supports (i.e. the purlins) when you walk across the ribs
  - Always take particular care when walking on wet or newly laid sheets particularly on steeply pitched roofs
- If roof is subjected to heavy floor traffic during construction, provision of temporary working platform can minimise damage to finishing of the roof material.



### Marking out

- A pencil of any color may be used except BLACK or so called LEAD pencils because the graphite content in black pencils can create an electric cell when wet and thus cause deterioration of the finish.
- Other recommended marking tools are a string line with chalk dust and a fine, felt-tipped marker.

### Cutting

- Use of a power saw with a metal cutting steel blade is the best way to cut sheets on site because it generates larger and cooler particles than abrasive discs.
- Where possible, cutting should be minimised by using factory supplied cut-to-length sheets.
- Sheets cut on site should, where practicable, be cut on the ground, with the exterior colour finish of prepainted sheet facing down. Care should be taken to ensure hot swarf does not come into contact with nearby clean COLORBOND® steel sheets.
- DO NOT cut over the top of other coated products where debris may fall onto clean sheets.
- Where cutting must be carried out near sheets already installed, the area around the cut must be masked and the stream of hot particles directed away from completed work.

### Drilling

The area around the hole should be masked to shield the product from hot swarf.

### Clean Up

Ensure that metallic particles are swept off sheet surfaces immediately following any cutting, drilling, etc.

## 2. GENERAL ROOFING INSTALLATION PROCEDURE

- Prior to commencement of fixing, the installer should ensure that purlins, girts or battens are truly in place and that the slope requirements are met. Any adjustments found necessary should be made prior to proceeding with fixing, as they will be difficult or impossible to rectify later.
  - When lifting sheets on to the roof frame ready for laying and fastening, care should be taken to make sure all sheets are the correct way up with the overlapping side towards the edge of the roof from which installation will commence. Otherwise sheets will have to be turned over and/or turned end for end. Sheet bundles should be placed over or near purlin supports, not at mid span of the purlins.
- The first sheet should be positioned with particular care before fastening, to ensure that it lies straight and square and is correctly located in relation to order building elements:
    - i. Transversely in relation to the barge-fascia or end-wall, bearing in mind the type of flashing or capping treatment to be used;
    - ii. Longitudinally in relation to gutter and ridge or barge-fascia or parapet or transverse wall.
  - Roof sheets should overhang about 50mm into gutters.

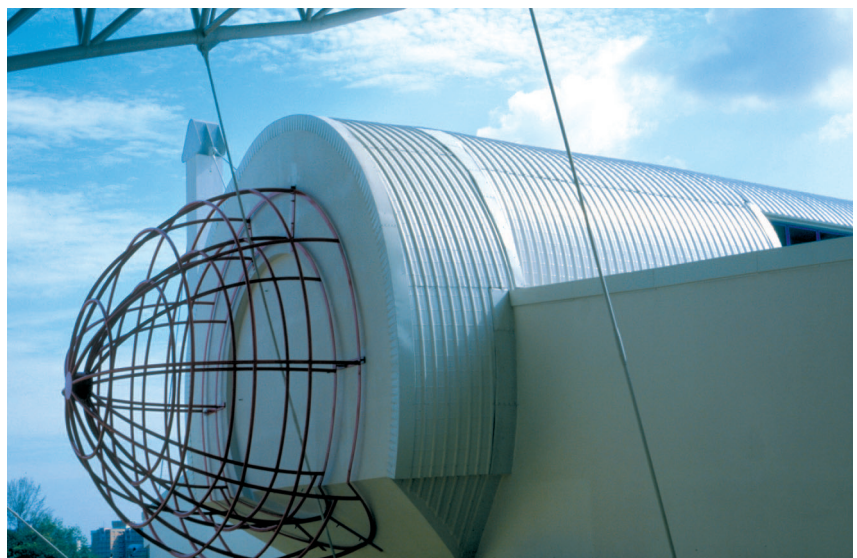

Choa Chu Kang Sport Complex, Singapore

### 3. INSTALLATION OF LYSAGHT® TRIMDEK®

- When lifting roofing sheets earlier onto roof frames, ready for installation, make sure either all male or all female ribs facing the same direction, otherwise sheets will have to be turned end-for-end during fixing.
- The first sheet of LYSAGHT® TRIMDEK® must be positioned with care before fastening with hex head self-tapping screws to ensure that it lies straight and square.
- When the first sheet is fastened in position, a string line can be stretched across the lower end of the roof alignment. The line will then be used as a guide for the subsequent roof panel for installation.
- Position and fasten the next roofing sheet to each support the male rib of the installed sheet. Place the second sheet over the second run of the roofing sheets and fastened the sheets together before proceeding to the next sheet.
- Make sure the side lapping is installed correctly. The side rib with the longitudinal anticapillary flute (male rib) supposed to be covered by the side rib without a longitudinal flute (female rib).

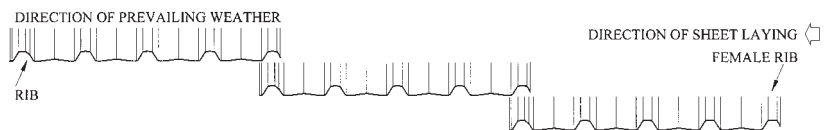

- Each sheet should be fully fastened before proceeding to the next sheet. The side lap with preceding sheet should be fastened last.
- In the case that two or more shorter sheets installed to provide full-length coverage due to handling or transport considerations, lay each complete line of sheets in turn from gutter/eaves to ridge.

#### TIPS FOR INSPECTION

- ✓ Identify the type of roofing profile used
- ✓ Look out for any sign of corrosion to perforation
- ✓ Look out for any detachment of fasteners from roof and steel purlins/ structures
- ✓ Look out for any detachment of related flashing and capping
- ✓ Look out for roof penetrations such as vent pipes and trapdoors if there is any water stagnation
- ✓ Look out for any debris left during construction such as screws, nails and other other trades debris
- ✓ Look out for the type of lightning conductor used (lead and copper are non- compatible materials)
- ✓ Look out for disengagement of LYSAGHT® TRIMDEK® roof panel from each other
- ✓ Look out for deteriorated sealant used
- ✓ Look out for wall and flashing/capping abutments
- ✓ Look out for end laps and side laps of roof and flashing/capping



Fixing of walling applications is similar to roofing

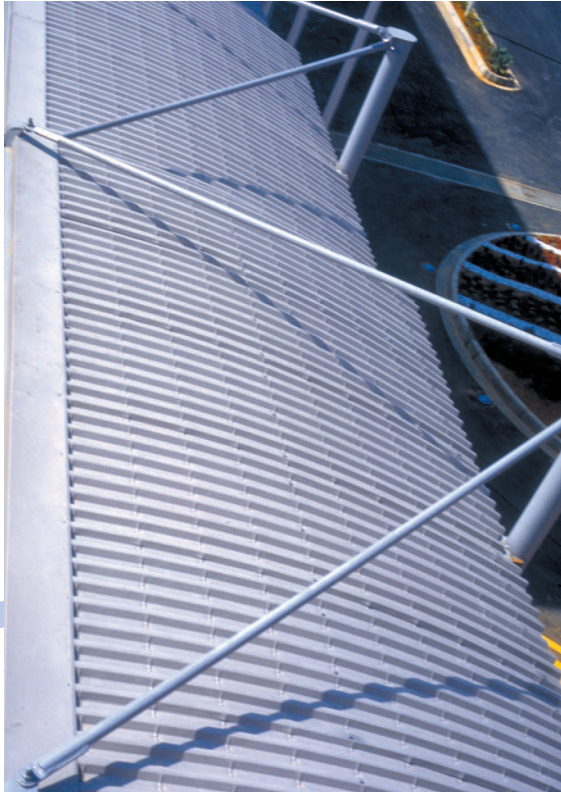

Linkway @ Bishan Stadium, Singapore

Nanning International Airport, PRC



Project in Malaysia



Star Automotive Centre, Singapore



Project in Malaysia



# Trusted Partner for Building Systems

**NS BLUESCOPE LYSAGHT MALAYSIA SDN BHD**  
NO 6, PERSIARAN KEMAJUAN, SEKSYEN 16,  
40200 SHAH ALAM,  
SELANGOR DARUL EHSAN, MALAYSIA.  
**TEL: 603-5520 6600 FAX: 603-5520 6601**

## NORTHERN

1-2-9, KRYSTAL POINT CORPORATE PARK,  
JALAN TUN DR. AWANG,  
LEBUH BUKIT KECIL 6,  
11900 SUNGAI NIBONG,  
PENANG, MALAYSIA.  
**TEL: 604-646 9553 / 6653 FAX: 604-646 6855**

## SOUTHERN

235, JALAN MURNI 11,  
KAWASAN PERINDUSTRIAN MURNI,  
81400 SENAI,  
JOHOR, MALAYSIA.  
**TEL: 607-598 7600 FAX: 607-598 7604**

**NS BLUESCOPE LYSAGHT SABAH SDN BHD**  
LORONG KURMA OFF JALAN KOLOMBONG,  
88450 KOTA KINABALU,  
SABAH, MALAYSIA.  
**TEL: 6088-445 161 FAX: 6088-421 178**

## NS BLUESCOPE LYSAGHT (SARAWAK) SDN BHD KUCHING

LOT 610, SECTION 66, PENDING INDUSTRIAL AREA,  
JALAN MERBAU, 93450 KUCHING,  
SARAWAK, MALAYSIA.  
**TEL: 6082-333 621 FAX: 6082-483 486**

## BINTULU

LOT 974, BLOCK 26 KLD,  
KIDURONG LIGHT INDUSTRIAL ESTATE,  
97000 BINTULU, SARAWAK, MALAYSIA.  
**TEL: 6086-251 736 FAX: 6086-252 881**

[www.lysaght.com.my](http://www.lysaght.com.my)  
[mysupport@bluescope.com](mailto:mysupport@bluescope.com)  
For more information, please contact:  
**1700-81-8688**



**NS BLUESCOPE LYSAGHT SINGAPORE PTE LTD**  
(Formerly known as BlueScope Lysaght (Singapore) Pte Ltd.)  
18 BENOI SECTOR,  
JURONG TOWN,  
SINGAPORE 629851  
**TEL: 65-6264 1577 FAX: 65-6265 0951**

[www.lysaght.com.sg](http://www.lysaght.com.sg)

**NS BLUESCOPE LYSAGHT (BRUNEI) SDN BHD**  
INDUSTRIAL COMPLEX,  
BERIBI PHASE 1,  
6KM, JALAN GADONG,  
BANDAR SERI BEGAWAN BE 1118,  
BRUNEI DARUSSALAM.  
**TEL: 673-244 7155 FAX: 673-244 7154**

[www.bluescopelysaght.com.bn](http://www.bluescopelysaght.com.bn)



COATING



COLOUR CHOICES



DESIGN FLEXIBILITY



DURABILITY / SECURITY



HI-TECH PRODUCTION



RECYCLING



TERMITE PROOF



THERMAL EFFICIENCY



WARRANTY