

The Lysaght logo is positioned in the top right corner. It features the word "LYSAGHT" in a bold, white, sans-serif font. A white swoosh underline is positioned beneath the letters "AGHT". The background of the entire page is a dark blue with a faint, technical architectural drawing overlay. A large, light-colored image of the Klip-Lok Optima cladding panels is shown in a perspective view, occupying the left and center of the page. A diagonal white line separates this image from a blue-shaded area on the right.

LYSAGHT

A large, close-up photograph of Lysaght Klip-Lok Optima cladding panels. The panels are light-colored with a ribbed texture and are arranged in a perspective view, showing their interlocking design. The image is set against a dark blue background with a faint architectural drawing overlay.

**LYSAGHT®
KLIP-LOK OPTIMA™**

The text "The Widest Concealed-Fixed Cladding" is located in the bottom right corner. It is written in a white, sans-serif font and is set against a dark blue background. The text is positioned within a blue-shaded area that is separated from the rest of the page by a diagonal white line.

The Widest
Concealed-Fixed
Cladding

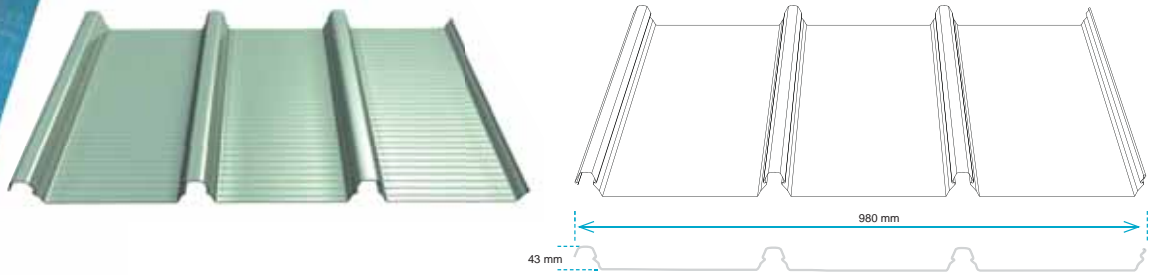

WIDER SPANNING BETTER EFFICIENCY

LYSAGHT® KLIP-LOK OPTIMA™ is the new generation of high-strength cladding that spans wider and offers better uplift performance than other comparable profiles. Our extensive research shows that its concealed fixing system and long lengths make it the best profile for controlling thermal expansion and contraction. A patented innovation, the wide-cover LYSAGHT® KLIP-LOK OPTIMA™ ensures economy as well as ease of installation and is suitable for both general and coastal environments.

SIMPLE. LOW-COST, CONCEALED-FIXING

With no exposed fasteners, the long, straight lines of LYSAGHT® KLIP-LOK OPTIMA™ remain clean and smooth.

At the heart of our system is our fixing clip, which can be laid in place and fixed simpler and faster than ever before. This is because the KL98 clip is fixed with hex. head screws, which are easier to drive.

The clip gives roofers the ability to accommodate up to 50mm of insulation.

TRANSVERSE FLUTING

Our patented transverse fluting significantly adds to the performance of this revolutionary product, making it superior to any other concealed-fixed cladding.

Longitudinal fluting is also available from the mobile rollformer for long length spring-curved applications.

PHYSICAL PROPERTIES

	STANDARD		NON-STANDARD
	Base Metal Thickness (mm)	0.42	0.48
Total Coated Thickness (mm)	0.47	0.53	0.65
Mass per Unit Area – COLORBOND® Steel (kg/m ²)	4.39	4.98	6.15
Mass per Unit Area – ZINCALUME® Steel (kg/m ²)	4.32	4.90	6.08
Coating Class (min)	AZ150		
Grade of Steel (MPa)	G550 (550MPa minimum yield stress)		
Effective Cover Width	980mm		
Rib Depth	43mm		
Min Recommended Roof Pitch/ Slope	2° (1 in 30)		
Tolerances	Length +0.0mm, -15.0mm / Width ± 4.0mm		
Custom Cut Lengths	Any measurement to a maximum transportable length. Long length is available for roll on site.		

PRODUCT BENEFITS

- Concealed fastening offers excellent water tightness and control of thermal expansion.
- Visually, a bold rib makes a strong statement rising from flat pans which are transverse micro-fluted.
- We have patented this outstanding innovation. LYSAGHT® KLIP-LOK OPTIMA™ is truly a superior product.

PERFORMANCE

MAXIMUM ALLOWABLE SUPPORT SPACING

Type of Span	Without Edge Stiffeners			With Edge Stiffeners		
	BMT (mm)			BMT (mm)		
	0.42	0.48	0.60	0.42	0.48	0.60
Roofs (mm)						
Single Span	850	1000	1500	850	1000	1500
End Span	900	1200	1500	1050	1200	1500
Internal Span	1450	2200	3000	1450	2200	3500
Unstiffened Eaves Overhang	150	200	250	150	200	250
Stiffened Eaves Overhang	450	500	550	450	500	550
Walls (mm)						
Single Span	1550	2000	2500	1900	2400	2500
End Span	1550	2300	2700	1900	2500	2700
Internal Span	2700	3600	3600	3075	3600	3600
Overhang	150	200	250	150	200	250

- For roofs: the data are based on foot-traffic loading.
- For walls: the data are based on pressures (see wind pressures table).
- Table data are based on supports of 1mm BMT.
Basic wind speed (Strength Limit State) = 57m/sec
Terrain category co-efficient = 0.83
Shielding factor = 0.85
Topography factor = 1
Design wind speed Strength Limit State (with above factors) = 40.2m/sec
Basic wind speed (Strength Limit State) = 40m/sec
Terrain category co-efficient = 1
Shielding factor = 1
Topography factor = 1
Design wind speed Strength Limit State (with above factors) = 40m/sec

Walls

$C_{pe} = -0.65$, $K_1 = 2$ for single and end spans, $K_1 = 1.5$ for internal spans
 $C_{pi} = +0.2$

Roofs

$C_{pe} = -0.9$, $K_1 = 2$ for single and end spans, $K_1 = 1.5$ for internal spans
 $C_{pi} = +0.2$

These spacings may vary by Serviceability and Strength Limit States for particular projects.

MAXIMUM ROOF LENGTHS FOR DRAINAGE MEASURED FROM RIDGE TO GUTTER (m)

Peak Rainfall Intensity (mm/hr)	Roof Slope (degrees)					
	2	3	4	5	8	10
100	502	588	663	732	873	1003
150	334	392	442	488	582	669
200	251	294	331	366	436	502
250	201	235	265	293	349	401
300	167	196	221	244	291	334
400	125	147	166	183	218	251
500	100	118	133	146	175	201

Penetrations will alter the flow of water on a roof. For assistance in design of roofs with penetrations, please seek advice from Lysaght representative.

LIMIT STATE WIND PRESSURE CAPACITIES (kPa) – WITHOUT EDGE STIFFENER

0.42mm BMT											
TYPE OF SPAN	LIMIT STATE	SPAN (mm)									
		900	1200	1500	1800	2100	2400	2700	3000	3300	3600
Single	Serviceability	0.96	0.85	0.75	0.66	0.56	0.49	0.41	0.34	0.28	-
	Strength*	2.02	1.85	1.69	1.52	1.36	1.21	1.07	0.92	0.78	-
End	Serviceability	0.85	0.83	0.80	0.76	0.71	0.64	0.57	0.50	0.43	0.35
	Strength*	1.86	1.73	1.58	1.39	1.20	1.04	1.00	0.97	0.94	0.91
Internal	Serviceability	0.78	0.76	0.74	0.72	0.68	0.64	0.59	0.54	0.50	0.45
	Strength*	1.91	1.76	1.61	1.45	1.31	1.19	1.10	1.05	1.00	0.98

0.48mm BMT											
TYPE OF SPAN	LIMIT STATE	SPAN (mm)									
		900	1200	1500	1800	2100	2400	2700	3000	3300	3600
Single	Serviceability	1.11	1.00	0.89	0.79	0.69	0.59	0.50	0.41	0.32	-
	Strength*	2.40	2.12	1.85	1.61	1.40	1.25	1.13	1.04	0.97	-
End	Serviceability	1.20	1.18	1.14	1.05	0.94	0.82	0.71	0.62	0.53	0.45
	Strength*	2.34	2.29	2.25	2.01	1.68	1.39	1.33	1.27	1.22	1.16
Internal	Serviceability	1.18	1.17	1.15	1.10	0.99	0.87	0.77	0.69	0.64	0.58
	Strength*	2.21	2.15	2.03	1.79	1.52	1.30	1.28	1.27	1.26	1.24

0.60mm BMT											
TYPE OF SPAN	LIMIT STATE	SPAN (mm)									
		900	1200	1500	1800	2100	2400	2700	3000	3300	3600
Single	Serviceability	1.72	1.53	1.34	1.16	0.99	0.83	0.67	0.53	0.38	-
	Strength*	3.74	3.39	3.05	2.73	2.41	2.11	1.82	1.53	1.25	-
End	Serviceability	1.77	1.76	1.69	1.54	1.33	1.12	0.95	0.81	0.70	0.60
	Strength*	3.58	3.05	2.57	2.20	1.90	1.67	1.46	1.30	1.20	1.10
Internal	Serviceability	2.03	1.94	1.82	1.67	1.49	1.32	1.16	1.00	0.86	0.72
	Strength*	3.25	3.21	3.06	2.73	2.30	1.90	1.63	1.48	1.40	1.36

* A capacity reduction factor of 0.9 is applied to strength capacities.

These capacities are based on tests conducted at BlueScope Steel's NATA registered testing laboratory using a direct pressure testing rig.

LIMIT STATE WIND PRESSURE CAPACITIES (kPa) – WITH EDGE STIFFENER

0.42mm BMT											
TYPE OF SPAN	LIMIT STATE	SPAN (mm)									
		900	1200	1500	1800	2100	2400	2700	3000	3300	3600
Single	Serviceability	2.05	1.65	1.29	0.96	0.70	0.52	0.39	0.32	0.26	-
	Strength*	5.16	4.70	4.25	3.83	3.44	3.10	2.81	2.53	2.27	-
End	Serviceability	1.44	1.20	1.01	0.87	0.79	0.72	0.64	0.55	0.45	0.34
	Strength*	3.64	2.79	2.07	1.60	1.32	1.17	1.09	1.05	1.04	1.05
Internal	Serviceability	0.97	0.85	0.74	0.71	0.69	0.67	0.64	0.59	0.53	0.46
	Strength*	2.92	2.26	1.74	1.48	1.40	1.38	1.33	1.24	1.12	0.99

0.48mm BMT											
TYPE OF SPAN	LIMIT STATE	SPAN (mm)									
		900	1200	1500	1800	2100	2400	2700	3000	3300	3600
Single	Serviceability	2.57	2.07	1.60	1.19	0.85	0.62	0.46	0.36	0.29	-
	Strength*	7.13	6.07	5.07	4.19	3.51	3.07	2.81	2.68	2.63	-
End	Serviceability	1.73	1.54	1.36	1.18	1.03	0.89	0.77	0.66	0.56	0.47
	Strength*	3.78	3.26	2.74	2.24	1.81	1.48	1.40	1.33	1.26	1.18
Internal	Serviceability	1.43	1.19	1.02	1.01	0.98	0.94	0.89	0.81	0.69	0.56
	Strength*	3.65	2.76	2.10	2.00	1.90	1.80	1.76	1.65	1.29	1.29

0.60mm BMT											
TYPE OF SPAN	LIMIT STATE	SPAN (mm)									
		900	1200	1500	1800	2100	2400	2700	3000	3300	3600
Single	Serviceability	3.56	2.78	2.05	1.42	1.03	0.71	0.53	0.43	0.38	-
	Strength*	8.80	7.34	5.96	4.78	3.90	3.71	3.53	3.33	3.15	-
End	Serviceability	2.54	2.33	2.09	1.79	1.46	1.17	0.95	0.80	0.69	0.61
	Strength*	4.63	3.85	3.14	2.54	2.06	1.70	1.45	1.30	1.19	1.12
Internal	Serviceability	2.08	1.81	1.61	1.58	1.56	1.54	1.44	1.26	1.04	0.78
	Strength*	4.29	3.81	3.33	2.88	2.48	2.15	1.92	1.76	1.64	1.55

* A capacity reduction factor of 0.9 is applied to strength capacities.

These capacities are based on tests conducted at BlueScope Steel's NATA registered testing laboratory using a direct pressure testing rig.

LIMIT STATES WIND PRESSURES

LYSAGHT® KLIP-LOK OPTIMA™ offers the full benefits of the latest methods for modelling wind pressures. The wind pressure capacity table is determined by full scale tests conducted at BlueScope Lysaght's NATA-registered testing laboratory, using the direct pressure-testing rig.

Testing was conducted in accordance with AS 1562.1 - 1992 Design and Installation of Sheet Roof and Wall Cladding - Metal, and AS 4040.2 – 1992 Resistance to Wind Pressure for Non-cyclonic Regions.

The pressure capacities for serviceability are based on a deflection limit of $(\text{span}/120) + (\text{maximum fastener pitch}/30)$.

The pressure capacities for strength have been determined by testing the cladding to failure (ultimate capacity). These pressures are applicable when the cladding is fixed to a minimum of 1.0mm, G550 steel.

For material less than 1.0mm thick, seek advice from Lysaght representative.

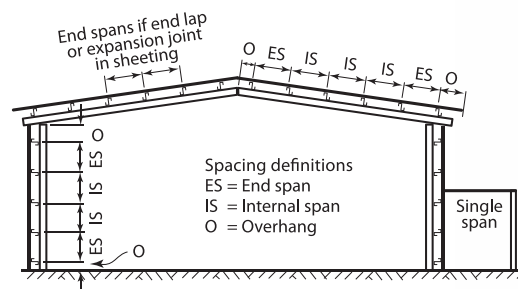

METHOD STATEMENT AND GENERAL NOTES

WALKING ON ROOFS

Keep your weight evenly distributed over the soles of both feet to avoid concentrating your weight on either heels or toes. Always wear smooth soft-soled shoes; avoid ribbed soles that pick up and hold small stones, swarf and other objects.

Be careful when moving between supports. Do not walk in the pan immediately adjacent to flashings or translucent sheeting. Walk at least one pan away.

ADVERSE CONDITIONS

If this product is to be used in marine, severe industrial, or unusually corrosive environments, ask for advice from Lysaght representative.

METAL & TIMBER COMPATIBILITY

Lead, copper, free carbon, bare steel and green or some other chemically treated timbers are not compatible with this product. Don't allow any contact of the product with those materials, nor discharge of rainwater from them onto the product. Supporting members should be coated to avoid problems with underside condensation. If there are doubts about the compatibility of other products being used, ask for advice from Lysaght representative.

MAINTENANCE

Optimum product life will be achieved if all external walls are washed regularly. Areas not cleaned by natural rainfall (such as the tops of walls sheltered by eaves) should be washed down every six months.

STORAGE AND HANDLING

Keep the product dry and clear off the ground. If stacked or bundled product becomes wet, separate it, wipe it with a clean cloth to dry thoroughly.

Handle materials carefully to avoid damage: don't drag materials over rough surfaces or each other; don't drag tools over material; protect from swarf.

TURN UP-DOWN TOOLS

On all roofs of pitches less than 15 degrees, the high end of all sheets must be turned up to stop water from being driven under the flashing and into the building.

Similarly, the pans at the gutter end must be turned down to stop water running back along the underside of the sheets.

Tools are available for both applications.

NOTCHING TOOL

A tool is available for on-site notching of transverse flashings and cappings.

CUTTING

For cutting thin metal on site, we recommend a circular saw with a metal cutting blade because it produces fewer damaging hot metal particles and leaves less resultant burr than a carborundum disc does.

Cut materials over the ground and not over other materials.

Sweep all metallic swarf and other debris from roof areas and gutters at the end of each day and at the completion of the installation. Failure to do so can lead to surface staining when the metal particles rust.

FASTENERS

Fasteners without insulation		
Fixing to steel up to 0.75mm BMT	Fixing to steel > 0.75mm to 3mm BMT	Fixing to timber
Self-drilling, self-tapping screws 12 - 14 x 30 OR Type 17 Self screws with hex & washer-head 12 – 11 x 25	Self-drilling, self-tapping screws with hex & washer-head 12 - 14 x 30	Self-drilling, self-tapping wood screws with hex & washer-head Softwood: 12 – 11 x 40 Hardwood: 12 – 11 x 25
Note: Use two screws per clip.		

Where insulation is to be installed, you may need to increase the length of the screws given below, depending on the density and thickness of the insulation.

When the screw is properly tightened:

- into metal: there should be at least three threads protruding past the support you are fixing to, but the Shankguard must not reach that support;
- into timber: the screw must penetrate the timber by the same amount that the recommended screw would do if there were no insulation;
- Fasteners should comply to AS3566, Class 3 or Class 4.

SEALED JOINTS

For sealed joints use screws or rivets and neutral-cure silicone sealant branded as suitable for use with galvanised or ZINCALUME® steel.

END LAPS/ EXPANSION JOINTS

LYSAGHT® KLIP-LOK OPTIMA™ is designed to minimize water penetration, and therefore, highly not recommended for end-lapping. If you are designing for more than maximum transportable length, LYSAGHT® KLIP-LOK OPTIMA™ can be rolled on-site. Please contact your nearest BlueScope Lysaght office for more information.

EXTRA VERSATILITY OF MOBILE ROLLFORMING

The mobile rollformer delivers on-site rolling for extra long lengths. In some cases, the mobile rollformer has the unique ability to 'roll-to-roof' saving you time and money for transport and craneage.

INSTALLATION

PREPARATION

Before starting work ensure that:

- The supports for your cladding are truly in the same plane;
- The minimum roof slopes conform to our recommendations; and
- The overhangs of sheets from the top and bottom supports don't exceed our recommendations.
- The first and last supports and clips should be at least 75mm from each end of the sheet to keep maximum holding power.

Make any necessary adjustments before you start laying sheets, because they will be difficult to rectify later.

ORIENT SHEETS BEFORE LIFTING

Consider which end of the building is best to start from. For maximum weather-tightness, start laying sheets from the end of the building that will be downwind of the worst-anticipated or prevailing weather (Figure 1).

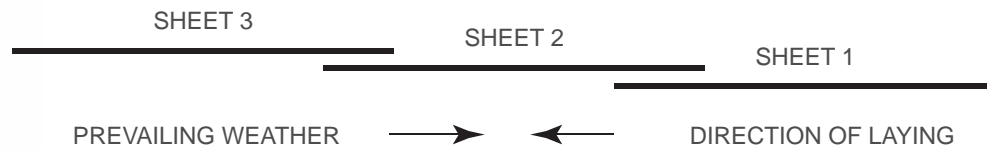

Figure 1
Lay sheets towards prevailing weather

It is much easier and safer to turn sheets on the ground than up on the roof. Before lifting sheets on to the roof, check that they are the correct way up and the overlapping side is towards the edge of the roof from which installation will start.

Place bundles of sheets over or near firm supports, not at mid span of roof members.

STEPS FOR INSTALLATION

1. Lay and fix wire mesh to the supports in accordance with the appropriate building requirements. (Figure 2)
2. Position the first clips on each support by placing onto the support nearest the gutter. (Figure 3)
3. Fix the first clip on the support so they point in the direction of laying. Ensure the clip is 90 degrees to the edge of the sheet.
4. Align the clips with the spacer using a string line (or the first sheet as a straight edge) to align the clips as you fix a clip to each support working towards the high end of the roof.
5. Drive hex-head screws through the top of the clip, into the support.
6. Work along the edge of the gutter, ensuring it aligns correctly at its ends in relation to the gutter and ridge (or parapet or transverse wall).
7. Place the glass wool insulation between the supports.
8. Measure the distance from the gutter end of the sheet to the support.
9. Position the first sheet so that it overhangs the desired amount (usually 50mm) to the gutter. It is important to ensure this first sheet is placed square to adjacent edges. (Figure 4.)
10. Engage the sheet with clips using vertical foot pressure on all the ribs over each clip. (Figure 5)
11. Fix the next row of clips, one to each support with the slots and tabs engaged. Be sure the clip is 90 degrees to the edge of the sheet.
12. As before, place the next sheet over its clips ensuring you also engage the edge of the preceding sheet.
13. Accurately position the sheet so that it overhangs the desired amount into the gutter. It is important that you keep the gutter-end of all sheets in a straight line.
14. Fully engage the two sheets along the overlapping rib. You can do this by walking along the full length of the sheet with one foot in the center pan of the previous sheet and the other foot applying vertical pressure to the top of the interlocking ribs at regular intervals. It is important that you don't walk in the unsupported pan beside the overlap (Figure 5)
15. Similarly, engage all the clips by applying vertical foot pressure to the top of the other two ribs over each clip.

It is essential that the sheets interlock completely. It is important that your weight is fully on the sheet you are installing.

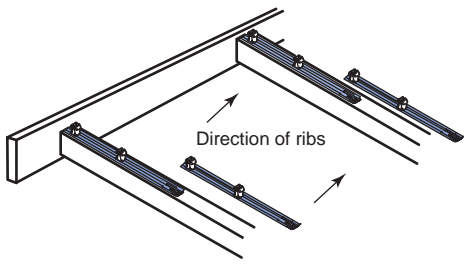

Figure 2
Fix the first rows of clips. Fix the next (and subsequent) clips and sheets.

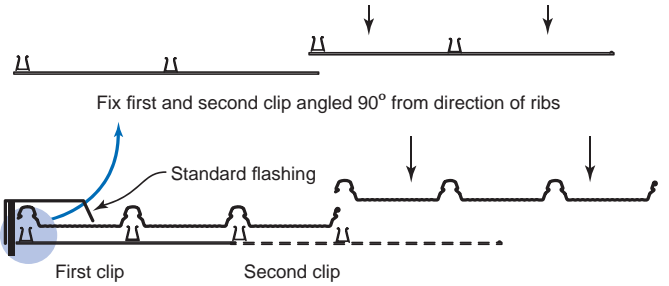

Figure 3
Place first sheet on clip and snap onto clip. Add subsequent clips and sheets as required.

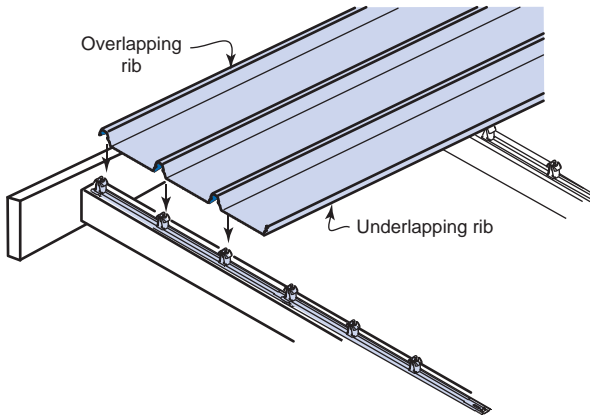

Figure 4
Placing the first sheet

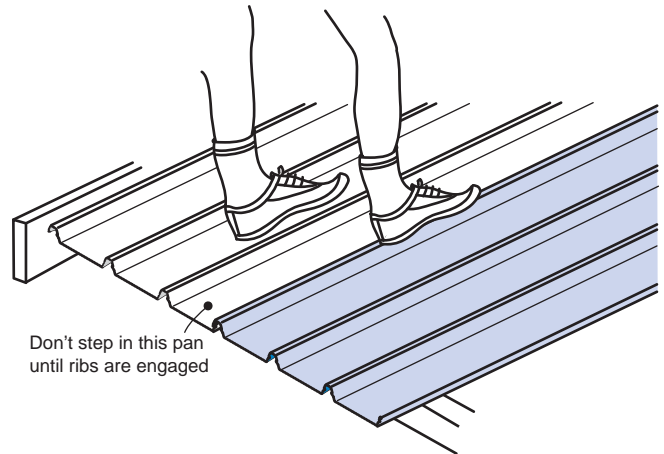

Figure 5
Engaging the lapping ribs

CHECK ALIGNMENT OCCASIONALLY

Occasionally check that the sheets are still parallel with the first sheet, by taking two measurements across the width of the fixed sheeting.

At about halfway through the job, perform a similar check but take the measurements from the finishing line to aim for the final sheet to be parallel with the end of the roof. If the measurements are not close enough, lay subsequent sheets very slightly out of parallel to gradually correct the error. (Figure 6) To allow this to happen, flatten the tabs on the base of subsequent clips - the slot in the clip will allow the clips to be fixed out of standard pitch.

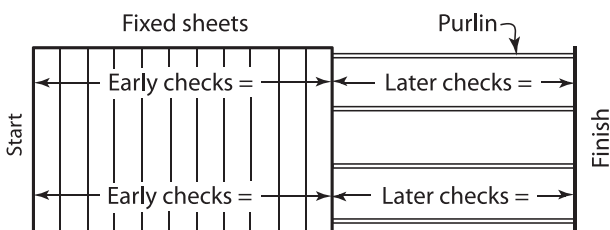

Figure 6
Check alignment occasionally

FIX THE LAST SHEET

If the final space is less than the full width of a sheet, you can cut a sheet along its length and shorten the clips as appropriate. It is desirable to fix the sheet at one end.

INSTALLING LYSAGHT® KLIP-LOK OPTIMA™ WALLS

The installation procedure for walls is similar to that described for roofs. To prevent LYSAGHT® KLIP-LOK OPTIMA™ from sliding downward in the fixing clips, you should pierce-fix through each sheet under the flashing or capping, along the top of the sheets.

INSTALLING TRANSLUCENT SHEETS WITH LYSAGHT® KLIP-LOK OPTIMA™

Because of its greater thermal expansion, translucent cladding should be fixed using oversized holes and sealing washers recommended by the cladding manufacturer. When used with concealed fixed claddings, ensure the fasteners do not penetrate the steel cladding. There are translucent products available that easily accommodate this.

Note: Don't exceed the maximum support spacing specified by the translucent cladding manufacturer. Use of translucent sheeting may result in lower limit state capacities.

LYSAGHT® RAINWATER GOODS

Whether you're searching for a distinctive look for a new home or looking for an economic solution for a large commercial project BlueScope Lysaght offer an extensive range of rainwater solutions.

Our domestic rainwater goods are manufactured from ZINCALUME® steel with COLORBOND® steel colours available, so they'll stand up to years of the harshest Australian climate.

The choice of colours and styles is extensive, covering everything you could need from gutters and downpipes, to fascia, flashings and cappings, as well as fasteners and fixing clips.

COMMERCIAL/INDUSTRIAL DRAINAGE SYSTEMS

There is a standard procedure for designing the drainage of a roof using an eaves & gutter system. It is assumed that the gutters will have a gradient steeper than 1:500. Box gutter systems can be more complex and are thoroughly treated in AS/NZS 3500.3.2:1998.

We manufacture the perfect guttering system for your structure, whichever type is appropriate.

All designs can be complemented with our complete range of square and round downpipes and rainwater accessories. To ensure quick and easy installation there is also a full range of matching fixing clips.

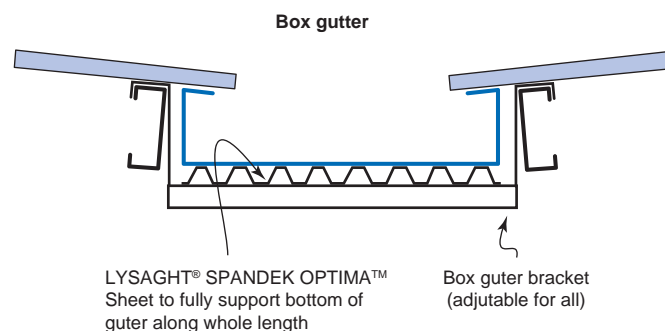

A TOTAL SOLUTION

NS BlueScope Lysaght provides a broad range of roofing and rainwater products for industrial building solutions which complement long length LYSAGHT® KLIP-LOK OPTIMA™. Our gutter systems can be tailor-made for your project.

WHY YOU SHOULD ALWAYS INSIST ON BLUESCOPE LYSAGHT

When you specify LYSAGHT® products you have the added advantage of dealing with a company whose expertise and experience with steel stretches back for well over a century. A company with a reputation for consistently producing top quality products at competitive prices.

Our products are backed by a performance warranty* for up to 25 years. When a NS BlueScope Lysaght warranty* is granted, it guarantees in writing that your products will perform exactly to specifications when installed and maintained in accordance with our recommendations.

* Warranty terms and conditions apply.

NON-CYCLONIC AREAS

The information in this brochure is suitable for use only in areas where a tropical cyclone is unlikely to occur as defined in AS 1170.2-2002. Map and table (below) taken from HB212-2002.

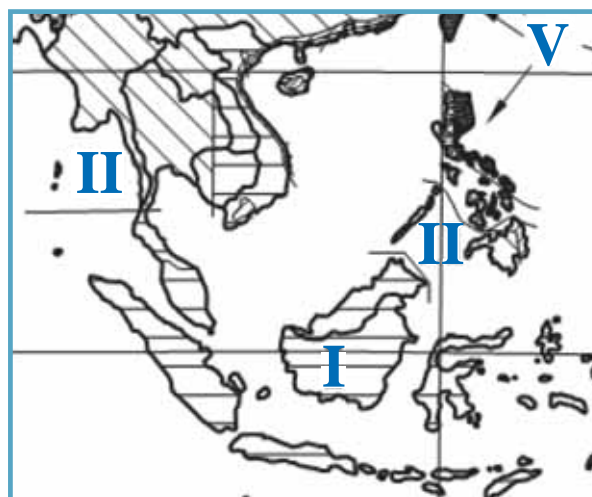

Wind speeds versus return period (3 s gust, 10 m height, open country terrain)

Handbook Level	Description	Equation for V_R	V_{50}	V_{500}
I	Strong thunderstorms and monsoon winds	$70 - 56R^{-0.1}$	32	40
II	Moderately severe thunderstorms and extra-tropical gales	$67 - 41R^{-0.1}$	39	45
III	Severe thunderstorms and moderate or weakening typhoons/tropical cyclones	$106 - 92R^{-0.1}$	44	57
IV	Strong typhoons/ tropical cyclones	$122 - 104R^{-0.1}$	52	66
V	Very strong typhoons/ tropical cyclones	$156 - 142R^{-0.1}$	60	80

Table summarises the proposed relationships between 3 s gust wind speed and return period for the five levels in the handbook (see map). The values are for 50 years and 500 years return periods.

COLORBOND® STEEL AND ZINCALUME® STEEL

STRONG BRANDS, QUALITY MATERIALS

LYSAGHT® products are made of highest quality material, namely COLORBOND® steel and ZINCALUME® steel which are the leading materials for external cladding application. COLORBOND® steel and ZINCALUME® steel have been used on countless buildings to portray modern architecture works of art, ranges from the classic roofing to advance façade for industrial, commercial and residential buildings.

Colorbond®

COLORBOND® steel is a pre-painted finished product with ZINCALUME® steel substrate to deliver both superior corrosion resistance and excellent colour performance.

It comes with the THERMATECH® solar reflectance technology and Clean technology to minimize tropical dirt staining while lowering urban heat island effect, delivering longevity and minimal maintenance to your external cladding.

COLORBOND® steel is backed by a material warranty of up to 25 years*

Product Attributes

- Pre-painted finish on top of ZINCALUME® steel substrate to deliver superior corrosion resistance.
- Superior primer technology which prevents paint delamination.
- Proprietary super polyester paint system proven to provide excellent colour performance.
- Clean technology incorporated to resist against tropical dirt staining.
- THERMATECH® solar reflectance technology to allow for lower temperature cladding.
- Wide varieties of colours and finishes to cater for your building design needs.

Zincalume®

ZINCALUME® steel is a metallic coated steel product composed of 55% aluminium, 43.5% zinc and 1.5% silicon (aluminium-zinc alloy coating) that can provide superior corrosion resistance for your external cladding, with expected lifespan that's four times the life of generic alternatives (GI).

ZINCALUME® steel is backed by a material warranty of up to 25 years*

Product Attributes

- Superior corrosion resistance due to the minimum coating class of AZ150.
- Initial resistance to surface marking and wet storage corrosion due to the proprietary clear resin coating.
- Better aesthetics compared to generic alternatives (Al-Zn) due to less surface darkening, afforded by the proprietary clear resin coating.
- Lightweight and thermally efficient compared to conventional roofing materials (e.g. concrete and clay tiles)
- Excellent flexibility in design as steel can be bent and curved to form truly unique designs.

**Warranty terms and conditions apply*

This material warranty may vary to buildings nearer to marine or industrial environment and is subjected to prior agreement by BlueScope. For full terms and conditions and to determine the eligibility of your project for the warranty, please contact your Key Account Manager.

There are different internal and external environments affecting the longevity of COLORBOND® steel and ZINCALUME® steel, hence feel free to consult our material experts for more specialized recommendations.

Examples of recommendations:

- Direct contact between COLORBOND® steel or ZINCALUME® steel with copper, lead and stainless steel should be avoided.

If condensation on the reverse side of roofing sheet is likely, vapour barrier should be installed to shield COLORBOND® steel or ZINCALUME® steel from prolonged exposure to the condensation (moisture).

REFERENCES



CJ Bio Malaysia



Emporium Apartment Kuching



Design Village Outlet Mall, Penang



IJM Seremban 2 Residential



Hershey Chocolate Factory, Johor

REFERENCES



The New Kota Kinabalu High Court Complex



Mapletree Logistic Hub Shah Alam



Tenery Residence at Kuching





NS BLUESCOPE LYSAGHT MALAYSIA SDN BHD

Company No: 196801000301 (7896-D)

NO 6, PERSIARAN KEMAJUAN, SEKSYEN 16,
40200 SHAH ALAM,
SELANGOR DARUL EHSAN, MALAYSIA.
TEL: +603-5520 6600 FAX: +603-5520 6601/2

NORTHERN

1-2-9, KRYSTAL POINT CORPORATE PARK,
JALAN TUN DR. AWANG,
LEBUH BUKIT KECIL 6,
11900 SUNGAI NIBONG,
PENANG, MALAYSIA.
TEL: +604-646 9553 / 6653 FAX: +604-646 6853

SOUTHERN

BMS MALL - BLOCK A #02-08,
NO. 6, JALAN KENCANA MAS 2/1,
KAWASAN PERINDUSTRIAN TEBRAU III,
81100 JOHOR BAHRU,
JOHOR DARUL TAKZIM, MALAYSIA.
TEL: +607-355 1576/7/8
FAX: +607-355 1579

NS BLUESCOPE LYSAGHT SABAH SDN BHD

Company No: 197201001095 (12749-X)

LORONG KURMA OFF JALAN KOLOMBONG,
88450 KOTA KINABALU,
SABAH, MALAYSIA.
TEL: +6088-445 161 FAX: +6088-421 178



COATING



COLOUR CHOICES



DESIGN FLEXIBILITY



DURABILITY / SECURITY



HI-TECH PRODUCTION



RECYCLING



TERMITE PROOF



THERMAL EFFICIENCY



WARRANTY

NS BLUESCOPE LYSAGHT (SARAWAK) SDN BHD

Company No: 197701002868 (33837-P)

KUCHING
LOT 610, SECTION 66, PENDING INDUSTRIAL AREA,
JALAN MERBAU, 93450 KUCHING,
SARAWAK, MALAYSIA.
TEL: +6082-333 621 FAX: +6082-483 486

BINTULU

LOT 974, BLOCK 26 KLD,
KIDURONG LIGHT INDUSTRIAL ESTATE,
97000 BINTULU, SARAWAK, MALAYSIA.
TEL: +6086-251 736 FAX: +6086-252 881

NS BLUESCOPE LYSAGHT (B) SDN BHD

INDUSTRIAL COMPLEX,
BERIBI PHASE 1,
6KM, JALAN GADONG,
BANDAR SERI BEGAWAN BE 1118,
BRUNEI DARUSSALAM.
TEL: +673-244 7155 FAX: +673-244 7154

NS BLUESCOPE LYSAGHT SINGAPORE PTE LTD

18 BENOI SECTOR,
JURONG TOWN,
SINGAPORE 629851
TEL: +65-6264 1577 FAX: +65-6265 0951



www.lysaghtasean.com

Copyright © 2021 by BlueScope Steel Limited. All rights reserved. No part of this brochure shall be reproduced, stored in a retrieval system, or transmitted in any form or by any means, electronic, mechanical, photocopying, recording or otherwise, without written permission from BlueScope Steel Limited. LYSAGHT®, SPANDEK®, COLORBOND® and ZINCALUME® are registered trademarks and KLIP-LOK OPTIMA™ is a trademark of BlueScope Steel Limited. BlueScope is a trademark of BlueScope Steel Limited.

Apr 2021