

# LYSAGHT® TRIMDEK® OPTIMA™

Subtle square fluted steel  
cladding with extra-wide span

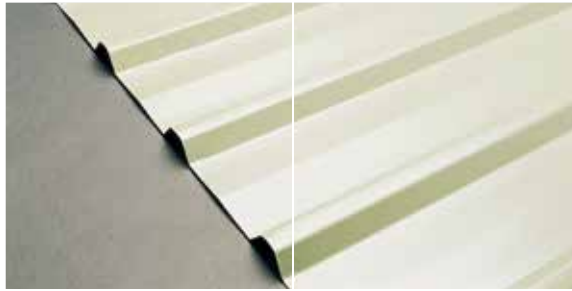

Structural Solutions



Roofing & Walling Solutions



House Framing Solutions

**LYSAGHT**

# LYSAGHT® TRIMDEK® OPTIMA™

Subtle square fluted steel cladding with extra-wide span



LYSAGHT® TRIMDEK® OPTIMA™ is a subtle square-fluted steel cladding, available in long lengths, so on most jobs you can have one sheet from ridge to gutter or full wall height without end laps.

The strength, spanning ability, lightness and rigidity of LYSAGHT® TRIMDEK® OPTIMA™ means wide support spacings can be used with safety.

LYSAGHT® TRIMDEK® OPTIMA™ is made of high strength steel and despite its lightness, provides excellent spanning capacity.

#### SIMPLE, LOW-COST FIXING

Long, straight lengths of LYSAGHT® TRIMDEK® OPTIMA™ can be lowered into place and aligned easily. Fixing with hexagon headed screws is simple and fast.

Finishes	Base Metal Thickness (mm)	Total Coated Thickness (mm)	kg/m	kg/m <sup>2</sup>
ZINCALUME® steel	0.42	0.47	4.23	4.16
COLORBOND® steel	0.42	0.47	4.30	4.24
ZINCALUME® steel	0.48	0.53	4.80	4.73
COLORBOND® steel	0.48	0.53	4.87	4.80

- Subtle square ribs and fluted pan roof and wall cladding are strong, durable and versatile.
- Available in long lengths so one continuous sheet may be used from ridge to gutter or full wall lengths without end laps.
- The fluting in the pans provides strength and long spanning capabilities.
- The strength, spanning ability, lightness and rigidity of LYSAGHT® TRIMDEK® OPTIMA™ means wide support spacings can be used with safety.
- Long spanning capacity allows cladding to be lowered into place and easily aligned.



## PRODUCT PROFILE

### MATERIAL SPECIFICATIONS

LYSAGHT® TRIMDEK® OPTIMA™ is made from:

- ZINCALUME® aluminium/zinc alloy-coated steel complying with AS-1397 - 2001 G550, AZ150 (550MPa minimum yield stress, 150g/m<sup>2</sup> minimum coating mass);

The Clean COLORBOND® steel complies with AS/NZS2728:1997.

### LENGTHS

Sheets are supplied custom cut.

### TOLERANCES

Length: + 0mm, - 15mm

Width: + 4mm, - 4mm

### COLOURS

LYSAGHT® TRIMDEK® OPTIMA™ is available in an attractive range of colours in COLORBOND® steel and in unpainted ZINCALUME® aluminium/zinc alloy-coated steel.

ZINCALUME® steel provides a minimum of twice the life of conventional galvanised steel in the same environment.

The standard COLORBOND® steel offers a full range of contemporary colours suitable for all building projects. COLORBOND® XPD steel provides superior aesthetic qualities, and COLORBOND® ULTRA steel is intended for severe coastal or industrial environments.

### MINIMUM ROOF PITCH

Long lengths and a special anti-capillary groove in the side lap allows you to use LYSAGHT® TRIMDEK® OPTIMA™ on roof pitches as low as 3 degrees (1 in 20).

## PHYSICAL PROPERTIES OF LYSAGHT® TRIMDEK® OPTIMA™

Steel Grade (MPa)	G550 (550MPa minimum yield stress)
Effective Width of Coverage	1015mm
Depth of Rib	28.5mm
Minimum Recommended Roof Pitch	3° (1 in 20)
Base Metal Thickness	0.42mm, 0.48mm

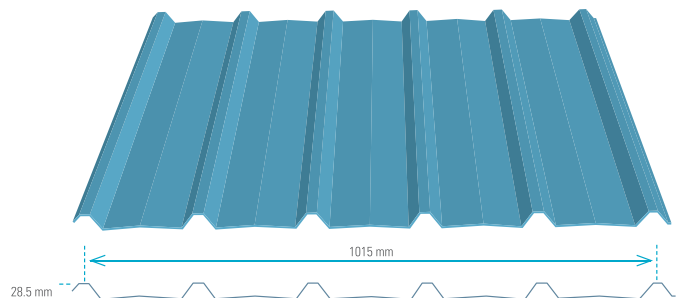

## PERFORMANCE

### MAXIMUM SUPPORT SPACINGS

LYSAGHT® TRIMDEK® OPTIMA™		
<b>Type of span</b>		
Base Metal Thickness (mm)	0.42	0.48
Total Coating Thickness (mm)	0.47	0.53
<b>Roof (mm)</b>		
Single Span	1200	1600
End Span	1900	2100
Internal Span	2500	3000
Unstiffened Overhang	150	150
Stiffened Overhang	250	250
<b>Walls (mm)</b>		
Single Span	2200	2300
End Span	2500	2700
Internal Span	3300	3300
Overhang	150	150

- For roofs: the data are based on foot-traffic loading.
- For walls: the data are based on pressures (see wind pressures table).
- Table data are based on supports of 1mm BMT.  
Basic wind speed (Strength Limit State) = 57m/sec  
Terrain category co-efficient = 0.83  
Shielding factor = 0.85  
Topography factor = 1  
Design wind speed Strength Limit State (with above factors) = 40.2m/sec  
Basic wind speed (Strength Limit State) = 40m/sec  
Terrain category co-efficient = 1  
Shielding factor = 1  
Topography factor = 1  
Design wind speed Strength Limit State (with above factors) = 40m/sec

### Walls

$C_{pe} = -0.65$ ,  $K_1 = 2$  for single and end spans,  $K_1 = 1.5$  for internal spans  
 $C_{pi} = +0.20$

### Roofs

$C_{pe} = -0.9$ ,  $K_1 = 2$  for single and end spans,  $K_1 = 1.5$  for internal spans  
 $C_{pi} = +0.20$

These spacings may vary by Serviceability and Strength Limit States for particular projects.

## MAXIMUM ROOF LENGTHS FOR DRAINAGE MEASURED FROM RIDGE TO GUTTER (m)

Peak rainfall intensity (mm/hr)	Roof Slope (degrees)				
	3	4	5	7.5	10
100	275	310	342	408	469
150	183	207	228	272	313
200	138	155	171	204	235
250	110	124	137	163	188
300	92	103	114	136	156
400	69	78	86	102	117
500	55	62	68	82	94

Penetrations will alter the flow of water on a roof. For assistance in design of roofs with penetrations, please seek advice from our information line.



Penang Sentral

## LYSAGHT® TRIMDEK® OPTIMA™ : LIMIT STATE WIND PRESSURE CAPACITIES (kPa)

LYSAGHT® TRIMDEK® OPTIMA™ 0.42mm BMT / 0.47mm TCT												
Span Type	Fasteners per sheet per support		For roofs (c/c) Span (mm)									
			600	900	1200	1500	1800	2100	2400	2700	3000	3300
Single	5	Serviceability	4.89	3.88	2.91	2.04	1.30	0.75	0.41	0.24	0.19	-
		Strength*	9.94	8.08	6.29	4.69	3.36	2.39	2.11	1.93	1.81	-
End	5	Serviceability	6.57	5.24	3.99	2.85	1.88	1.16	0.71	0.48	0.40	-
		Strength*	9.40	8.08	6.80	5.60	4.52	3.60	2.87	2.29	1.81	-
Internal	5	Serviceability	4.13	3.55	2.98	2.45	1.97	1.57	1.25	1.01	0.81	0.64
		Strength*	10.18	8.69	7.25	5.90	4.71	3.71	3.09	2.53	2.00	1.49

LYSAGHT® TRIMDEK® OPTIMA™ 0.48mm BMT / 0.53mm TCT												
Span Type	Fasteners per sheet per support		For roofs (c/c) Span (mm)									
			600	900	1200	1500	1800	2100	2400	2700	3000	3300
Single	5	Serviceability	6.69	5.28	3.93	2.72	1.69	0.93	0.47	0.25	0.19	-
		Strength*	11.27	9.04	6.91	5.02	3.47	2.39	2.35	2.30	2.24	-
End	5	Serviceability	7.79	6.25	4.79	3.46	2.33	1.47	0.93	0.64	0.52	0.49
		Strength*	11.34	9.79	8.29	6.88	5.59	4.49	3.59	2.87	2.25	1.69
Internal	5	Serviceability	5.93	4.99	4.08	3.24	2.51	1.91	1.48	1.17	0.95	0.78
		Strength*	11.84	10.41	9.03	7.69	6.43	5.27	4.23	3.29	2.42	1.58

\* A capacity reduction factor of 0.9 is applied to strength capacities.

These capacities are based on tests conducted at BlueScope Steel's NATA registered testing laboratory using a direct pressure testing rig. Supports must not be less than 1mm BMT.

## LIMIT STATES WIND PRESSURES

The wind pressure capacities are based on tests conducted at BlueScope Lysaght's NATA registered testing laboratory. Testing was conducted in accordance with AS 1562.1 - 1992 Design and Installation of Sheet Roof and Wall Cladding - Metal, and AS 4040.2 - 1992 Resistance to Wind Pressure for Non-cyclonic Regions.

The pressure capacities for serviceability are based on a deflection limit of (span/120) + (maximum fastener pitch/30).

The pressure capacities for strength have been determined by testing the cladding to failure (ultimate capacity).

These pressures are applicable when the cladding is fixed to a minimum of 1.0mm, G550 steel.

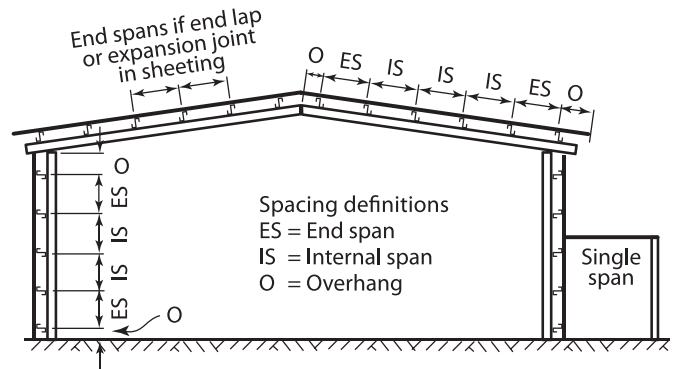

## METHOD STATEMENT AND GENERAL NOTES

### WALKING ON ROOFS

Generally, keep your weight evenly distributed over the soles of both feet to avoid concentrating your weight on either heels or toes. Always wear smooth soft-soled shoes; avoid ribbed soles that pick up and hold small stones, swarf and other objects.

Whatever direction you walk, always walk in the pans. When walking across the width of the roof, walk over, or close to, the roof supports.

Fasteners without Insulation			
	Fixing to steel up to 0.75mm BMT	Fixing to steel >0.75mm to 3mm BMT	Fixing to timber
Crest fixed	Self drilling screws with hex. washer-head & EPDM seal, 12 - 11 x 50 (M5.5 - 11 x 50)	Self drilling screws with hex. washer-head & EPDM seal, 12 - 14 x 50 (M5.5 - 14 x 50) OR 12 - 14 x 55 (M5.5 - 14 x 55)	Type 17 Self drilling screws with hex. washer-head, <i>Softwood:</i> 12 - 11 x 65 (M5.5 - 11 x 65) <i>Hardwood:</i> 12 - 11 x 50 (M5.5 - 11 x 50)
Valley fixed	Self drilling screws with hex. washer-head & EPDM seal, 10 - 12 x 20 (M4.8 - 12 x 20) OR Self drilling screws with hex. washer-head & EPDM seal, 10 - 16 x 16 (M4.8 - 16 x 16)	Self drilling screws with hex. washer-head & EPDM seal, 12 - 14 x 20 (M5.5 - 14 x 20)	Type 17 Self drilling screws with hex. washer-head & EPDM seal <i>Softwood:</i> 10 - 12 x 30 (M4.8 - 12 x 30) <i>Hardwood:</i> 10 - 12 x 20 (M4.8 - 12 x 20)
Side lap & accessories	Self drilling hex. head screws with washer & EPDM seal	10 - 16 x 16 OR EPDM seal: 8 - 15 x 15	



Fasteners with Insulation			
	Fixing to steel up to 0.75mm BMT	Fixing to steel >0.75mm to 3mm BMT	Fixing to timber
Crest fixed	Self drilling screws with hex. washer-head & EPDM seal, 12 - 11 x 50 (M5.5 - 11 x 50)	Self drilling screws with hex. washer-head & EPDM seal, 12 - 14 x 65 (M5.5 - 14 x 65) OR 12 - 14 x 68 (M5.5 - 14 x 68)	Type 17 Self drilling screws with hex. washer-head, <i>Softwood:</i> 12 - 11 x 65 (M5.5 - 11 x 65) <i>Hardwood:</i> 12 - 11 x 50 (M5.5 - 11 x 50)
Valley fixed	Self drilling screws with hex. washer-head & EPDM seal, 10 - 12 x 20 (M4.8 - 12 x 20) OR Self drilling screws with hex. washer-head & EPDM seal, 10 - 16 x 16 (M4.8 - 16 x 16)	Self drilling screws with hex. washer-head & EPDM seal, 12 - 14 x 30 (M5.5 - 14 x 30)	Type 17 Self drilling screws with hex. washer-head & EPDM seal <i>Softwood:</i> 10 - 12 x 30 (M4.8 - 12 x 30) <i>Hardwood:</i> 10 - 12 x 20 (M4.8 - 12 x 20) <i>Softwood:</i> 12 - 14 x 30 (M5.5 - 14 x 30) <i>Hardwood:</i> 12 - 14 x 20 (M5.5 - 14 x 20)
Side lap & accessories	Self drilling hex. head screws with washer & EPDM seal	10 - 16 x 16 OR EPDM seal: 8 - 15 x 15	

## FASTENERS

LYSAGHT® TRIMDEK® OPTIMA™ requires 5 fasteners per sheet per support as shown below. Fasteners should comply to AS3566, Class 3 or Class 4.

### Roof - Screw fix through rib



### Wall - Screw fix through pan



## FASTENING SHEETS TO SUPPORTS

LYSAGHT® TRIMDEK® OPTIMA™ profile is pierce-fixed to timber or steel supports. This means that fastener screws pass through the sheeting.

You can place fasteners for LYSAGHT® TRIMDEK® OPTIMA™ through the crests or in the pans. To maximise watertightness, always place roof fasteners through the crests. For walling, you may use either crest- or valley-fixing.

Always drive the fasteners perpendicular to the sheeting, and in the centre of the corrugation or rib. Don't place fasteners less than 25mm from the ends of sheets.

## CURVING

### Crimp Curved Roof

Crimp curved LYSAGHT® TRIMDEK® OPTIMA™ steel cladding is designed to provide versatility and creativity to bring new and refreshing designs to commercial, industrial, civic and domestic building. This design freedom has resulted in significant cost savings in construction, mainly due to:-

- Less supporting framework required for fascias, parapets and roofs.
- Simplified and reduced work involved in installation of fascia cladding.
- Reduction or elimination of many flashing and cappings.
- Less cladding material required to cover a given curve.

Sheet Profile	Min Radius (mm)	Max Radius (mm)
<b>Concave Crimp Curve</b>		
0.42mm BMT/0.47mm TCT	550	2000
0.48mm BMT/0.53mm TCT	560	2000
<b>Convex Crimp Curve</b>		
0.42mm BMT/0.47mm TCT	450	2000
0.48mm BMT/0.53mm TCT	470	2000

LYSAGHT® TRIMDEK® OPTIMA™  
Profile Convex Crimp Curve

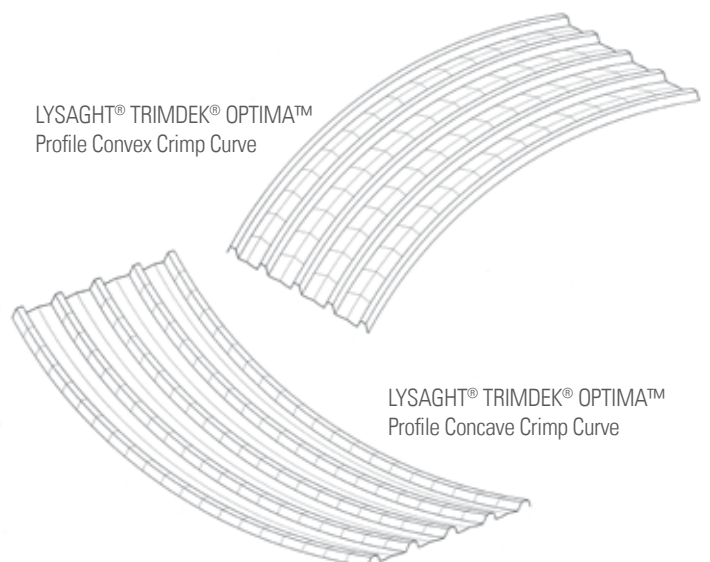

LYSAGHT® TRIMDEK® OPTIMA™  
Profile Concave Crimp Curve

## SUPPORT SPACINGS FOR CRIMP LYSAGHT® TRIMDEK® OPTIMA™ PROFILE (NON-CYCLONIC AREAS)

### STRAIGHT PORTION OF CRIMP CURVED LYSAGHT® TRIMDEK® OPTIMA™

- Maximum allowable spacings for the straight portion of crimp curved LYSAGHT® TRIMDEK® OPTIMA™ profile should follow the recommendations given at Maximum Support Spacings table.
- End spans refer to the spacing between the first and second supports from any free end of a sheet, except where that end of the sheet is crimp curve.
- The spacing between the supports either side of an end lap should be that as recommended for end spans.

### CRIMP CURVED PORTION OF CRIMP CURVED LYSAGHT® TRIMDEK® OPTIMA™

This will depend on the radius of curvature but the following guidelines are recommended:-

- For sheets curved to a radius of curvature not more than 3000mm, supports should be placed at centres not greater than 2100mm measuring around the arc of the curve.
- Where a curve of small included angle occurs (up to approximately 15°, for example at a ridge), support spacing should not exceed 1200mm.

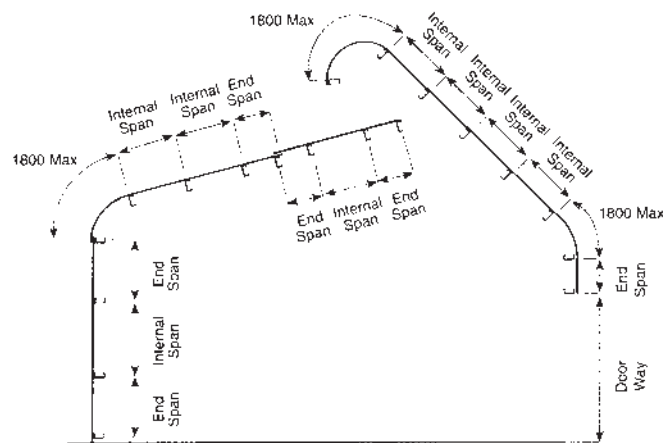

### REQUIREMENTS FOR CRIMP CURVED LYSAGHT® TRIMDEK® OPTIMA™ PROFILE

- Minimum curvature radius for convex is 450mm and 550mm for concave to underside or pan of sheet, minimum straight length of sheet at one end of curve is 180mm.

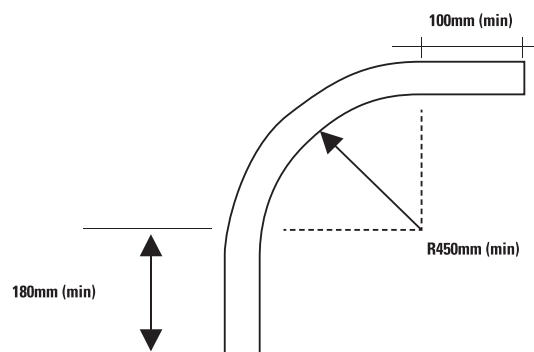

- Maximum length of sheet that can be crimp curved for ridge application is approximately 12000mm. The curve can either be convex or concave.

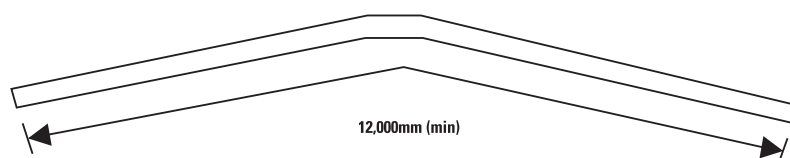

- The sheet can be crimp curved to three quarters of full circle but to facilitate side lapping, semi circle maximum is recommended.

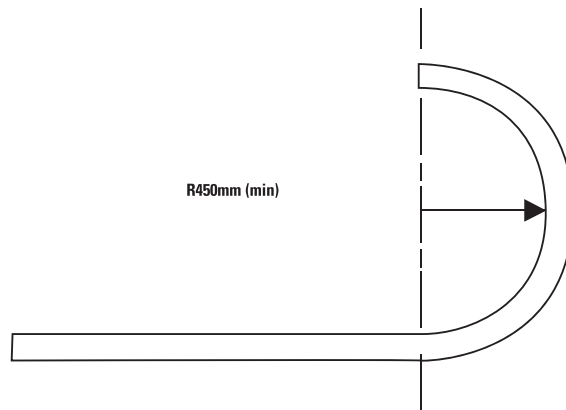

- When both ends are crimp curved, the maximum recommended straight distance between the two curves should be 6000mm.

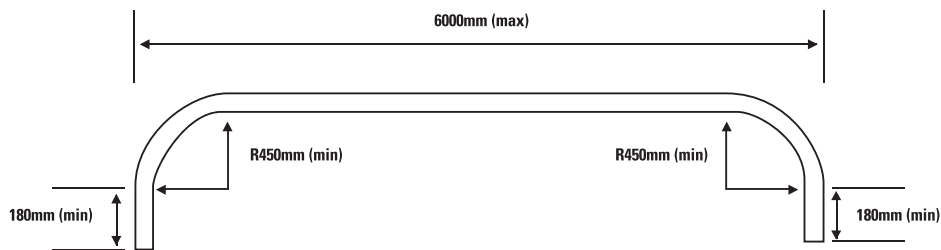

- For lengths exceeding 12000mm, please consult BlueScope Lysaght for more information.
- For easy transportation and maximum protection for the crimp curved sheets, the maximum height and length of the sheeting should be 2000mm and 11300mm respectively.

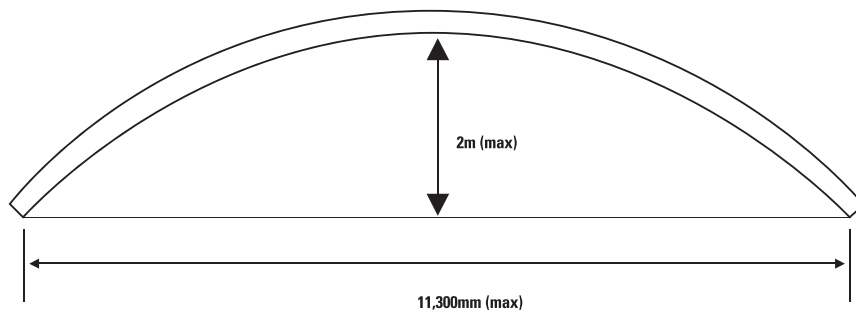

### SIDE-LAPS

The side of LYSAGHT® TRIMDEK® OPTIMA™ with the anti-capillary groove is always the underlap (see figures on this page). It is generally considered good practice to use fasteners along side-laps however, when cladding is supported as indicated in Maximum Support Spacings, side-lap fasteners are not usually needed for strength.

### END LAPPING

End-laps are not usually necessary because LYSAGHT® TRIMDEK® OPTIMA™ is available in long lengths.

If you want end-laps, seek advice from our information line on the sequence of laying and the amount of overlap.

### ENDS OF SHEETS

It is usual to allow roof sheets to overlap into gutters by about 50mm. If the roof pitch is less than 25° or extreme weather is expected, the pans of sheets should be turned-down at lower ends, and turned-up at upper ends by about 80°.

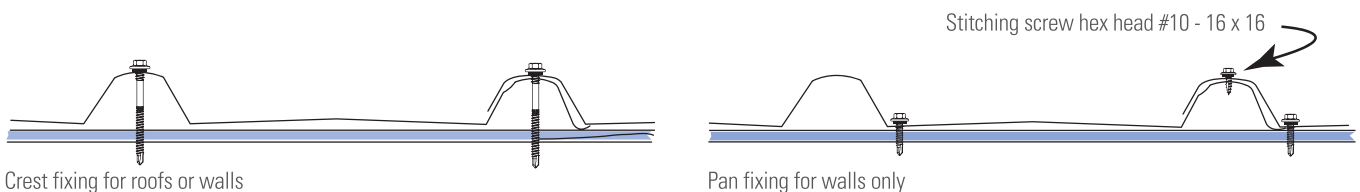

Crest fixing for roofs or walls

Pan fixing for walls only



## LAYING PROCEDURE

For maximum weather-tightness start laying sheets from the end of the building that will be in the lee of worst-anticipated or prevailing weather.

It is much easier and safer to turn sheets on the ground than up on the roof.

Before lifting sheets on to the roof, check that they are the correct way up and the overlapping side is towards the edge of the roof from which installation will start.

Place bundles of sheets over or near firm supports, not at mid span of roof members.

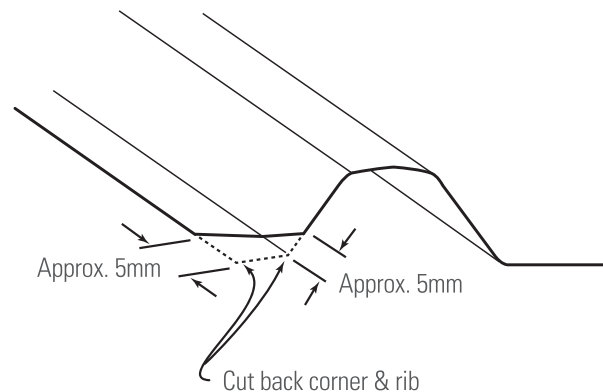

## SHEET-ENDS ON LOW SLOPES

When LYSAGHT® TRIMDEK® OPTIMA™ is laid on slopes of 5 degrees or less, cut back the corner of the under-sheet, at the downhill end of the sheet, to block capillary action.

## ADVERSE CONDITIONS

If this product is to be used in marine, severe industrial, or unusually corrosive environments, ask for advice from our information line.

## METAL & TIMBER COMPATIBILITY

Lead, copper, free carbon, bare steel and green or some chemically-treated timber are not compatible with this product. Don't allow any contact of the product with those materials, nor discharge of rainwater from them onto the product. Supporting members should be coated to avoid problems with underside condensation. If there are doubts about the compatibility of other products being used, ask for advice from our information line.

## MAINTENANCE

Optimum product life will be achieved if all external walls are washed regularly.

Areas not cleaned by natural rainfall (such as the tops of walls sheltered by eaves) should be washed down every six months.

A programme of roof maintenance is required to maintain any warranty offered.

## SAFETY, STORAGE AND HANDLING

LYSAGHT® product may be sharp and heavy.

It is recommended that heavy-duty cut resistant gloves and appropriate manual handling techniques or a lifting plan be used when handling material.

Keep the product dry and clear off the ground. If stacked or bundled product becomes wet, separate it, wipe it with a clean cloth to dry thoroughly.

Handle materials carefully to avoid damage: don't drag materials over rough surfaces or each other; don't drag tools over material; protect from swarf.

## CUTTING

For cutting thin metal on site, we recommend a circular saw with a metal-cutting blade because it produces fewer damaging hot metal particles and leaves less resultant burr than a carborundum disc.

Cut materials over the ground and not over other materials.

Sweep all metallic swarf and other debris from roof areas and gutters at the end of each day and at the completion of the installation. Failure to do so can lead to surface staining when the metal particles rust.

## SEALED JOINTS

For sealed joints use screws or rivets and neutral-cure silicone sealant branded as suitable for use with galvanised or ZINCALUME® steel.

## NON-CYCLONIC AREAS

The information in this brochure is suitable for use only in areas where a tropical cyclone is unlikely to occur as defined in AS 1170.2-2002. Map and table (below) taken from HB212-2002.



### Wind speeds versus return period

(3 s gust, 10m height, open country terrain)

Handbook Level	Description	Equation for $V_R$	$V_{50}$	$V_{500}$
I	Strong thunderstorms and monsoon winds	$70 - 56R^{-0.1}$	32	40
II	Moderately severe thunderstorms and extra-tropical gales	$67 - 41R^{-0.1}$	39	45
III	Severe thunderstorms and moderate or weakening typhoons/tropical cyclones	$106 - 92R^{-0.1}$	44	57
IV	Strong typhoons/tropical cyclones	$122 - 104R^{-0.1}$	52	66
V	Very strong typhoons/tropical cyclones	$156 - 142R^{-0.1}$	60	80

Table summarises the proposed relationships between 3 s gust wind speed and return period for the five levels in the handbook (see map). The values are for 50 years and 500 years return periods.



Frontier Industrial Park, Johor



BMW Car Showroom @ Desa Tebrau, Johor



## ZINCALUME® steel and COLORBOND® steel

Strong brands, quality materials

LYSAGHT® PRODUCTS ARE MANUFACTURED FROM HIGH QUALITY ZINCALUME® STEEL AND COLORBOND® STEEL, WHICH ARE LEADING BRANDS WITH A WIDE RANGE OF APPLICATIONS. THESE PRODUCTS HAVE BEEN USED WITH STRIKING EFFECT BY LEADING ARCHITECTS TO CREATE THE LATEST IN MODERN BUILDING DESIGNS, THROUGH TO CLASSIC ROOFING STYLES FOR RESIDENTIAL PROJECTS.

### Zincalume®

ZINCALUME® steel is a premium metallic coated steel product that is composed of 55% aluminium, 43.5% zinc and 1.5% silicon. The zinc/aluminium alloy coating on ZINCALUME® steel imparts corrosion resistance of up to four times the life of galvanised steel.

ZINCALUME® steel is backed by a material warranty of up to 25 years\*

Typical applications featuring ZINCALUME® steel include roofing, wall cladding and gutters.

#### Product Attributes

- Durable and strong.
- Superior corrosion resistance and has an excellent combination of physical and cut edge protection.
- Lightweight for easy handling.
- Thermally efficient roofing.
- Excellent flexibility in design, can be curved, for truly individual designs.
- Weather tight and secure when installed to manufacturer's specifications.
- Clear resin coating resists scuffing and handling marks.

\*Warranty terms and conditions apply

### Colorbond®

COLORBOND® pre-painted steel combines the superior strength of steel, the corrosion resistance and protection of a zinc/aluminium alloy (ZINCALUME® steel) coating that maintain its long lasting beauty with excellent colour retention.

It has been developed as a "Defence System Against Tropical Staining." Its unique oven-cured paint system prevents surface staining common to tropical environments caused mainly by temperature, moisture and air-borne contaminants.

COLORBOND® steel is backed by a material warranty of up to 25 years\*

#### Product Attributes

- Available in a range of attractive colours.
- The zinc/aluminium alloy coating on ZINCALUME® steel, plus the oven-baked, prepainted finish on COLORBOND® steel provide superior corrosion resistance for long life.
- Thermally efficient. Roofs made from COLORBOND® steel absorb less heat, thus cools very quickly.
- Light weight compared to concrete and clay tiles (on a per area basis) - reduced load on supporting structures.
- Excellent flexibility in design, can be curved, for truly individual designs.
- Flexibility of design allows for both traditional straight roof sheeting as well as innovative curved roofing designs.
- Resists cracking, chipping and peeling.

LEAD, COPPER and STAINLESS STEEL are not compatible with COLORBOND® steel and ZINCALUME® steel. Direct contact should therefore, be avoided. Where inside condensation conditions are likely, coated steel girts should be used so that any ZINCALUME® steel to bare steel contact is avoided.

Stainless steel fasteners are not recommended for ZINCALUME® and COLORBOND® steel.



# Trusted Partner for Building Systems

**NS BLUESCOPE LYSAGHT MALAYSIA SDN BHD**  
NO 6, PERSIARAN KEMAJUAN, SEKSYEN 16,  
40200 SHAH ALAM,  
SELANGOR DARUL EHSAN, MALAYSIA.  
**TEL: +603-5520 6600 FAX: +603-5520 6601/02**

## NORTHERN

1-2-9, KRYSTAL POINT CORPORATE PARK,  
JALAN TUN DR. AWANG,  
LEBUH BUKIT KECIL 6,  
11900 SUNGAI NIBONG,  
PENANG, MALAYSIA.  
**TEL: +604-646 9553 / 6653 FAX: +604-646 6853**

## SOUTHERN

BMS MALL - BLOCK A #02-08,  
NO. 6, JALAN KENCANA MAS 2/1,  
KAWASAN PERINDUSTRIAN TEBRAU III,  
81100 JOHOR BAHRU,  
JOHOR DARUL TAKZIM, MALAYSIA.  
**TEL: +607-355 1576/7/8 FAX: +607-355 1579**

**NS BLUESCOPE LYSAGHT SABAH SDN BHD**  
LORONG KURMA OFF JALAN KOLOMBONG,  
88450 KOTA KINABALU,  
SABAH, MALAYSIA.  
**TEL: +6088-445 161 FAX: +6088-421 178**

## NS BLUESCOPE LYSAGHT (SARAWAK) SDN BHD KUCHING

LOT 610, SECTION 66, PENDING INDUSTRIAL AREA,  
JALAN MERBAU, 93450 KUCHING,  
SARAWAK, MALAYSIA.  
**TEL: +6082-333 621 FAX: +6082-483 486**

## BINTULU

LOT 974, BLOCK 26 KLD,  
KIDURONG LIGHT INDUSTRIAL ESTATE,  
97000 BINTULU, SARAWAK, MALAYSIA.  
**TEL: +6086-251 736 FAX: +6086-252 881**

www.lysaghtasean.com  
lysaghtmalaysia@bluescope.com  
Customer Hotline:  
**1700-81-8688**



**NS BLUESCOPE LYSAGHT (B) SDN BHD**  
INDUSTRIAL COMPLEX,  
BERIBI PHASE 1,  
6KM, JALAN GADONG,  
BANDAR SERI BEGAWAN BE 1118,  
BRUNEI DARUSSALAM.  
**TEL: +673-244 7155 FAX: +673-244 7154**

**NS BLUESCOPE LYSAGHT SINGAPORE PTE LTD**  
18 BENOI SECTOR,  
JURONG TOWN,  
SINGAPORE 629851  
**TEL: +65-6264 1577 FAX: +65-6265 0951**



COATING



COLOUR CHOICES



DESIGN FLEXIBILITY



DURABILITY / SECURITY



HI-TECH PRODUCTION



RECYCLING



TERMITE PROOF



THERMAL EFFICIENCY



WARRANTY